

INSTRUCTION MANUAL

A6 Series

Electrical Hospital Bed with Digital Scale

7B01001200A6

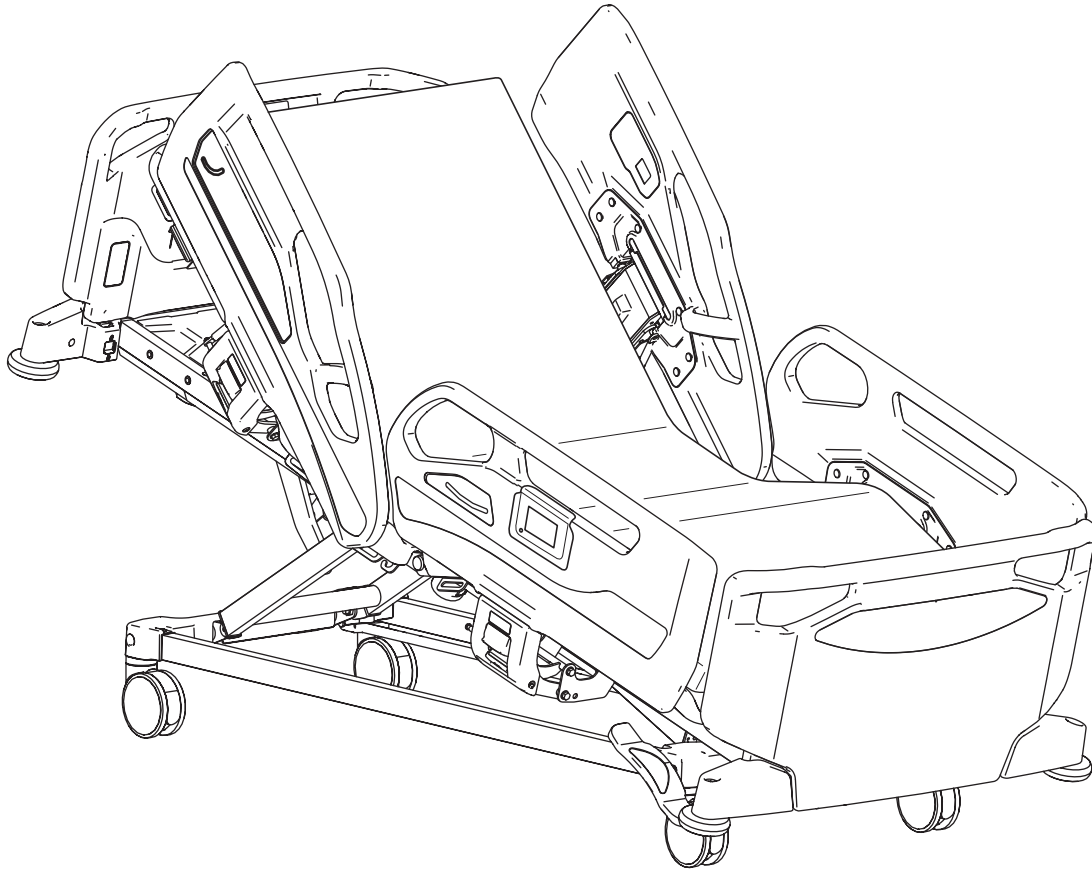

* An optional mattress is attached in the illustration.

Preface

Thank you for purchasing the **A6 Series Bed** (“bed”).

This instruction manual describes precautions and how to safely use and operate **the bed**.

- To ensure safe and proper use of the bed, be sure to read this instruction manual before use.
- The safe and correct operating procedures should be explained not only to the patient using the bed for medical treatment but also to the patient’s attendant.
- After reading this instruction manual, store it in a place that can be easily accessed for later reference.

CONTENTS

1 BEFORE USING THE BED	4
1. About this bed	4
• Intended use and benefits	4
• Part names	4
2. Safety precautions	7
3. Product symbol definitions	24
• Bed	24
• Side-rail integrated panel / Patient control panel	25
• Display panel	25
• Handheld controller (RC-1850E: accessory)	26
• Battery unit	26
4. Preparing the bed	27
• Detaching the transport brackets	27
• Attaching and detaching the headboard or footboard	28
• Side-rail.....	29
• Extension frame	31
• Locking casters	33
• Raising the foot end	34
• Accessory rail	35
• Restraint belt holder	36
• Accessory attachment hole	37
• Roller bumper	38
• Angle indicator	39
• Connecting to the power supply	40
• Battery unit	41
• Attaching and detaching the handheld controller (RC-1850E: accessory)	45
• Handheld controller hook	46
• Connecting the bed communication cable (commercially available product)	47
2 FUNCTIONS AND OPERATIONS	48
1. Bed functions	48
• Head up / Knee up / Head and knee coordination / Height adjustment	48
• Trendelenburg/reverse Trendelenburg	50
• Cardiac Chair motion	51
• BED EXIT ALARM	52
• X-ray cassette imaging (type with X-ray cassette tray only)	56

2. Operation procedure	59
• Using the side-rail integrated panel	59
• Using the patient control panel	65
3. DS display panel	68
• Part names	68
• SCALE	69
4. Emergency operation	74
• Lowering the head section with a CPR lever	74
3 SUITABLE PRODUCTS	75
1. Suitable products table	75
2. Mattress	76
3. Accessories	77
• Handheld controller	77
• BED Navi	82
• IV pole	83
• Oxygen cylinder holder	84
• Traction frame	86
• Orthopedic frame attachment	86
• Extension mattress	87
• Side-rail spacer/Foot spacer (PA-H6*1*, PA-H612* only).....	88
• Side-rail spacer holder	89
• Lifting pole	90
• Monitor table	91
• Drain bag holder	92
• Bed linen rack	93
• Chart holder	94
4. Peripherals	95
• Bedside table	95
• Overbed table	96
• Sittan™	96
• Electric patient lift (floor traveling)*1).....	97
4 IN CASE OF TROUBLE	98
1. Troubleshooting	98
2. Error codes	102
• Error code list	102

CONTENTS

5 REFERENCE INFORMATION	104
1. Regular inspection and daily maintenance	104
• Regular inspection	104
• Daily maintenance	105
2. Long-term storage and disposal	106
• Long-term storage	106
• Product disposal	106
3. Specifications	107
4. Technical explanation regarding EMD (Electromagnetic Disturbance)	118
5. After-sales service	122

<Notes>

- Some of the descriptions in this instruction manual may differ from the product you have purchased due to model improvements.
- Values described for the operation range, dimensions, angles, and weights are subject to normal manufacturing tolerances. Except for special cases, words such as approximately and about are omitted in this instruction manual to improve readability.
- For any queries, contact Paramount Bed (see p. 122) or your distributor.

1 BEFORE USING THE BED

1. About this bed

Intended use and benefits

[Intended use]

This bed is designed to help patients maintain a comfortable posture at medical institutions. Use the bed according to the patient's medical condition.

[Clinical benefit]

- Patient comfort
- Quality Patient Care and efficient care provision

[Patient target group]

- User weight (min. - max.): 40 kg to 180 kg
- Minimum user height: 146 cm
- Minimum user body mass index (BMI): 17
- Supported age range: 13 years and older
- * Do not use the bed for children (aged 12 or under) or patient weighing more than 180 kg.

[Intended users]

Medical professionals, patients, close relatives of patients, and maintenance staff

Part names



Numbers with this symbol mark indicate pages where a related explanation is provided.

* This illustration uses the long type Foot-end side-rail for explanation.

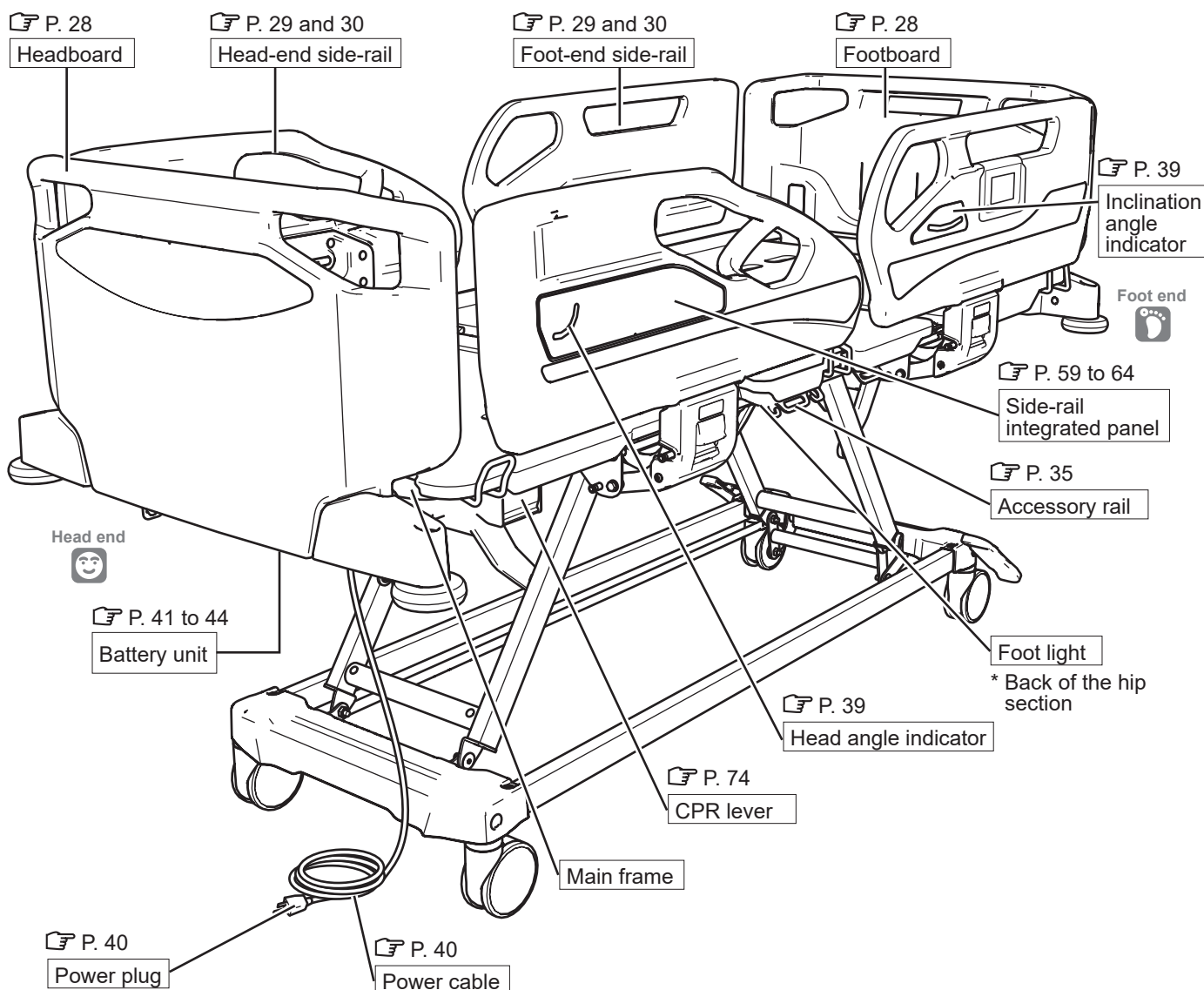

1 BEFORE USING THE BED

 Numbers with this symbol mark indicate pages where a related explanation is provided.

* This illustration uses the long type Foot-end side-rail for explanation.

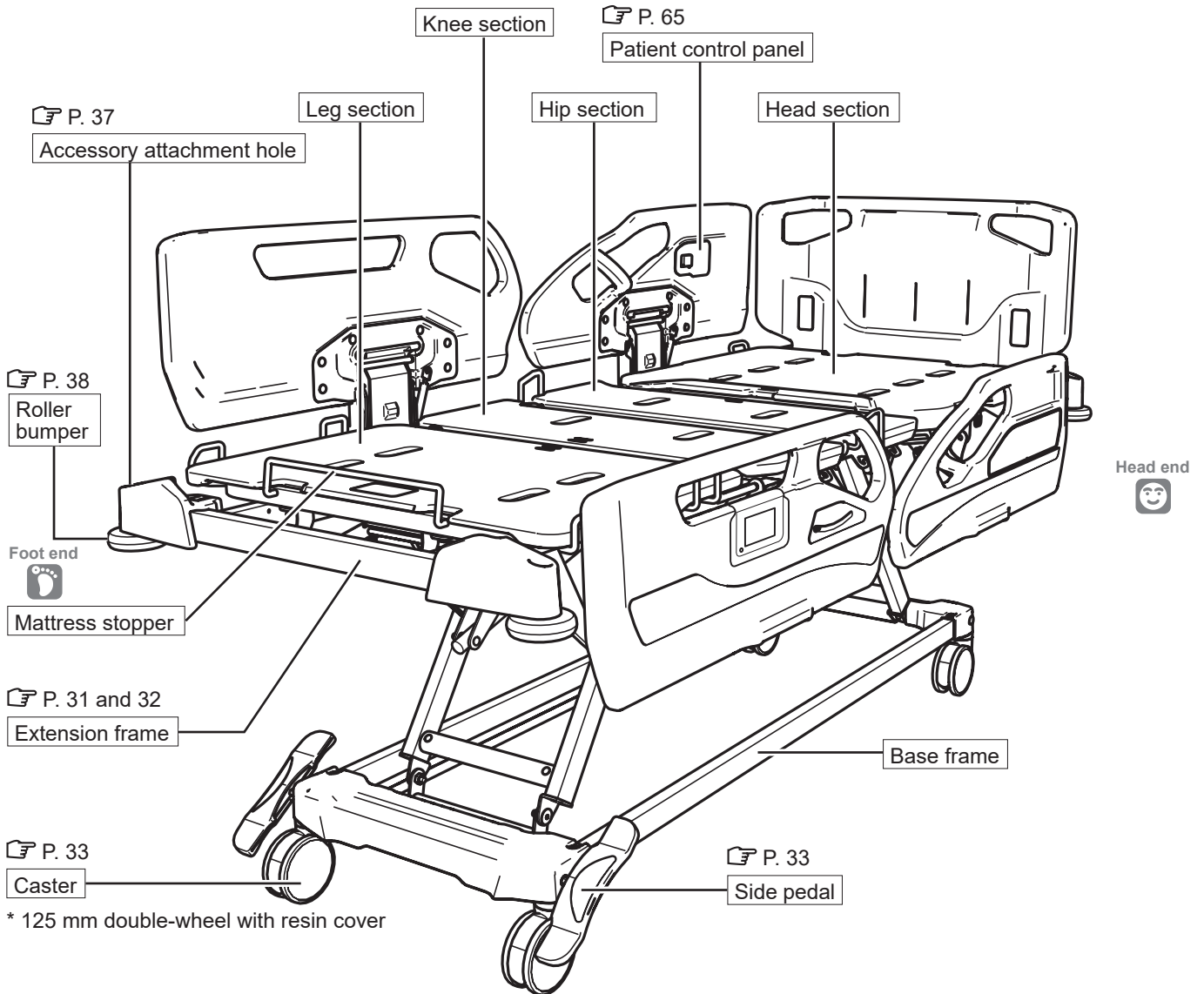

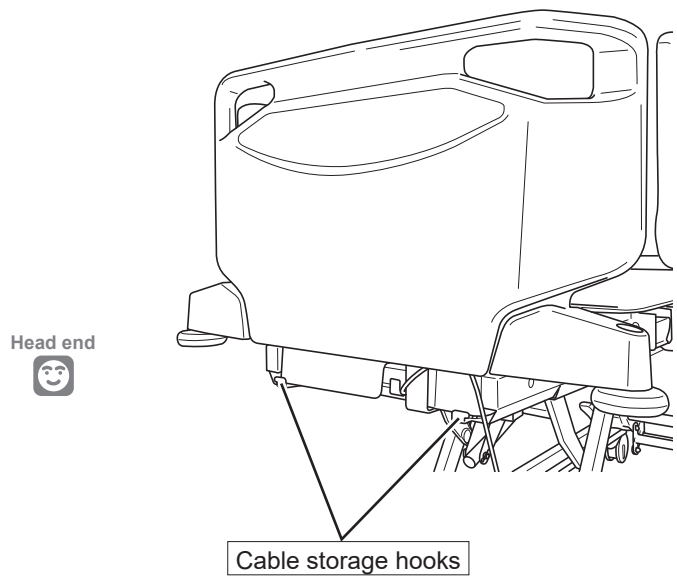

Applied parts

- * Parts of the bed that in normal use necessarily come into physical contact with the patient for the bed to perform its function

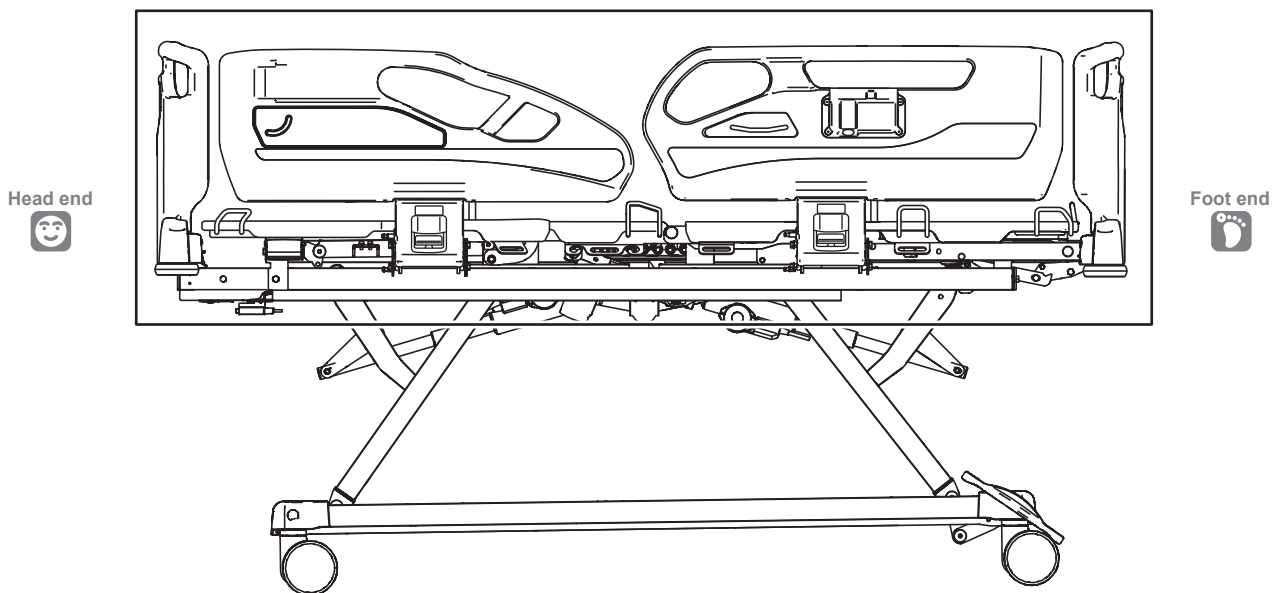

1 BEFORE USING THE BED

2. Safety precautions

Be sure to read these safety precautions beforehand to ensure proper use.

- The safety precautions described here are intended to ensure safe use of the product and prevent personal injury and property damage. Precautions are classified into “⚠ WARNING” and “⚠ CAUTION,” which indicate the degree of hazard or injury that could result from improper use. They are all important safety precautions that must be strictly observed.

 WARNING	Indicates that improper handling by ignoring this indication may cause death or serious injury (broken bones, pressure being applied, or paralysis).
 CAUTION	Indicates that improper handling by ignoring this indication may cause minor injuries (such as bruises, scratches, or cuts) or property damage.

* With regard to the items described in “Safety precautions,” <Gap related notes> (see p. 9 and 10) are especially important because ignoring them could result in serious life-threatening accidents. Be sure to read these notes and use the product safely and properly. Be especially careful to check a patient who might act in unexpected ways or cannot maintain their posture independently.

- * After reading this instruction manual, store it in a place that can be easily accessed for later reference.

<Safety labels>

- Warnings and precautions requiring special attention by persons using the bed are described on labels that are affixed inside of the footboard, the underside of the Foot-end side-rail, and at the top of the leg section. Do not remove or deface them.
- If a safety label is removed or defaced, replace it with a new one obtained from Paramount Bed (see p. 122) or your distributor.

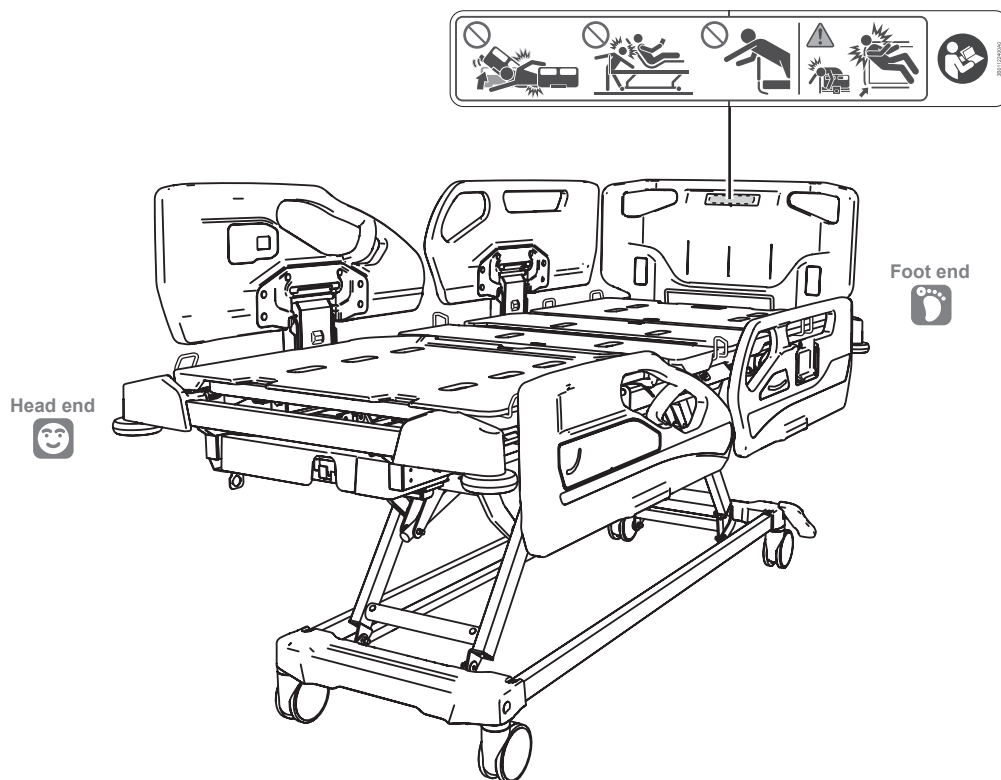

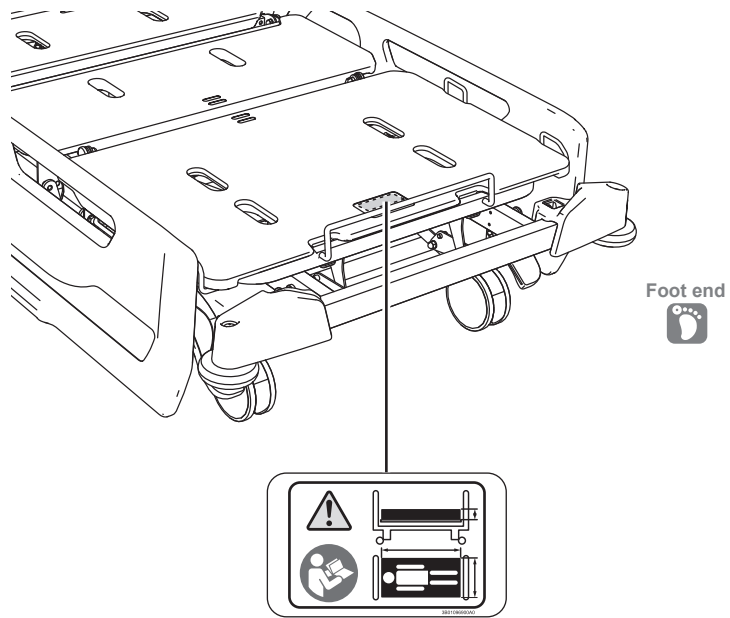
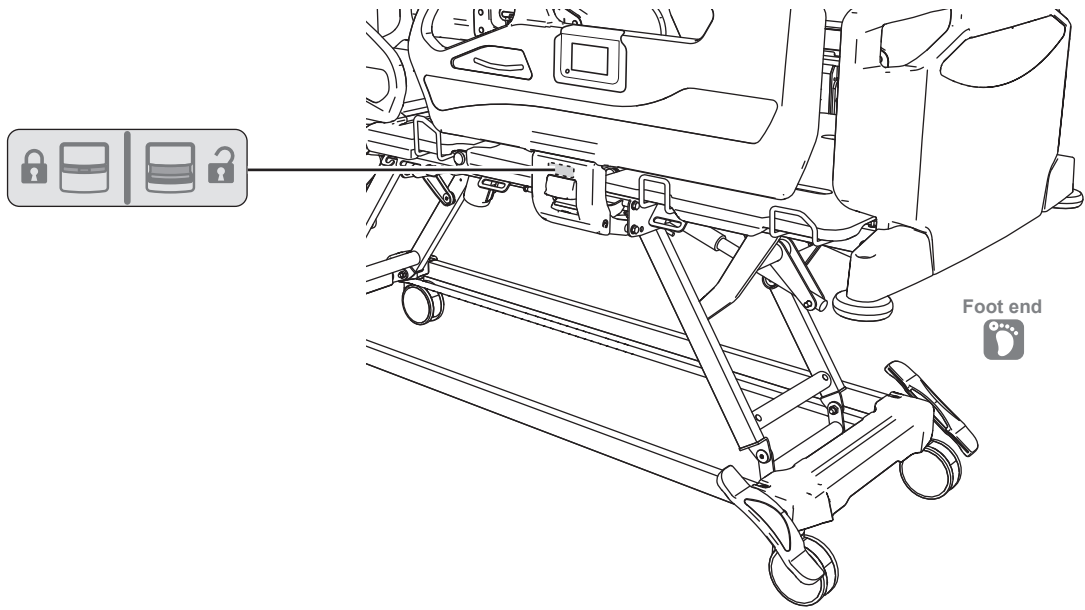

1 BEFORE USING THE BED



WARNING

<Gap related notes>

■ Watch the gaps.

- There are gaps in the bed, side-rail, etc. There is a risk of injury if part of the body (especially the head and neck) gets caught in those gaps.
- Be especially careful to check a patient who might act in unexpected ways or cannot maintain their posture independently.
- Pay attention to the following points.

- | | |
|---|--|
| ① Gap in side-rail | ⑥ Gap inside the board |
| ② Gap between side-rails (head end/foot end) | ⑦ Gap between board and mattress deck/
mattress |
| ③ Gap between side-rail and board | ⑧ Gap between raised mattress deck and
board/side-rail |
| ④ Gap between side-rail and mattress deck/
mattress (vertical direction) | ⑨ Gap between IV Pole/side-rail spacer/
Foot spacer/Traction frame and board/side-rail/
mattress deck/mattress |
| ⑤ Gap between side-rail and mattress deck/
mattress (horizontal direction) | |

* The figure shows an example.

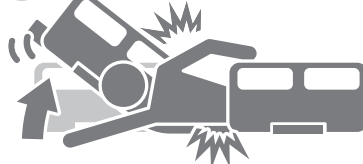
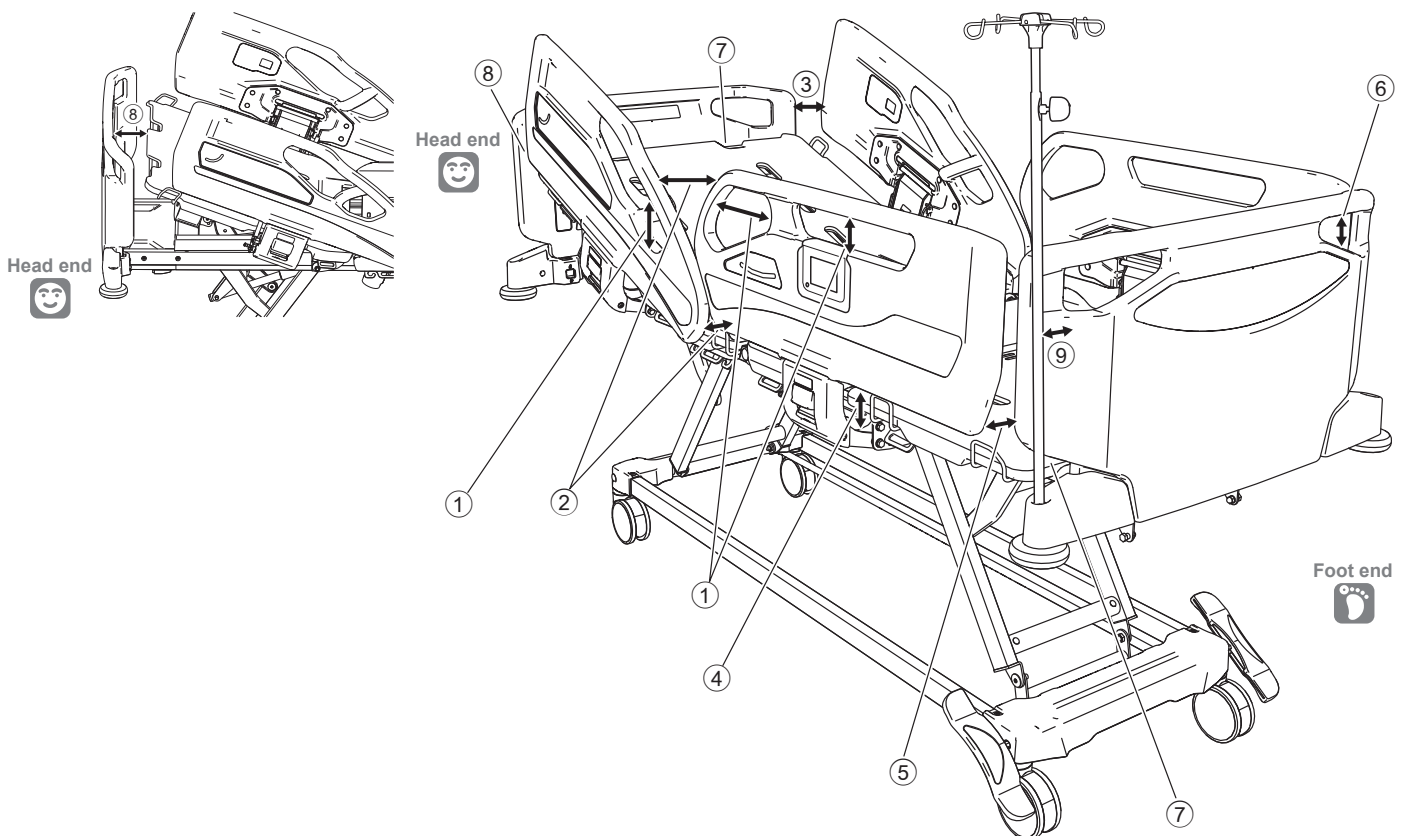



WARNING

■ Do not operate the bed with part of the body placed in a gap.



- A body part could get caught in a gap, resulting in injury.
- Be especially careful to check a patient who might act in unexpected ways or cannot maintain their posture independently.

■ Do not insert a hand (fingers) or legs between the bed frame and the mattress deck during bed operation.

- A body part could get caught in the gap between the lowered mattress deck and the bed frame or board, resulting in injury.
- Be especially careful to check a patient who might act in unexpected ways or cannot maintain their posture independently.

■ Be careful to prevent any part of the body from entering the gap between the bed and a wall or other objects.

- There is a risk that a part of the body may get caught, resulting in injury.
- Be especially careful to check a patient who might act in unexpected ways or cannot maintain their posture independently.

■ Do not crawl under the bed or place your head, hands, or legs under the bed.

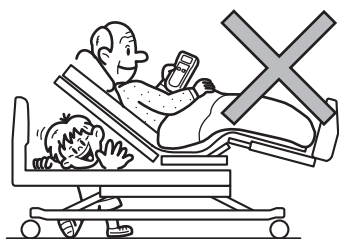

- A body part could get caught in the gap between the moving parts of the bed and the frame or side-rail, resulting in injury. Check to make sure there are no objects around the bed before operating the bed.
- Be especially careful to check a patient who might act in unexpected ways or cannot maintain their posture independently.

■ Check the patient's condition when adjusting the mattress deck angle or bed height.

If the patient moves while the mattress deck angle or bed height is adjusted, the patient may fall off the bed or get caught in a gap, resulting in injury. In particular, if the patient cannot maintain their posture independently, support their body when performing an adjustment.

■ When attaching a suitable product, make sure there are no foreign objects in the Accessory attachment holes.

If there are foreign objects, the accessory cannot be attached correctly and there is a risk of the patient falling off the bed, or unexpected gaps being created and part of the body getting caught, resulting in injury.

1 BEFORE USING THE BED



WARNING

<Falling off>

■ Be careful to prevent the patient from falling off the bed even when side-rails are raised.

- The patient may fall through a gap between side-rails, or between a board and side-rail, resulting in injury.
- The patient may bend forward over a side-rail and fall off the bed, resulting in injury.
- When a thick mattress is used, the effective height of the side-rails becomes lower. Be careful because this makes it easier for the patient to roll over them and fall, which may result in injury.
- Be especially careful to check a patient who might act in unexpected ways or cannot maintain their posture independently.

■ When transferring a patient, raise the side-rails.

The patient may fall off the bed, resulting in injury.

■ The side-rails should be operated by the nurse from outside the bed.

If the patient operates the side-rails from inside the bed, the side-rails may go down suddenly and the patient may fall off the bed, resulting in injury.

■ Do not sit on the side-rails, headboard, or footboard.

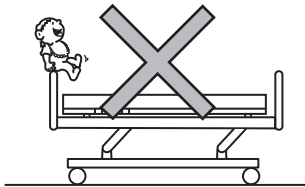

The patient could fall off the bed or fall down, or the bed or side-rails could be damaged or deformed, resulting in injury.

■ When leaving the bed area or taking your eyes off the patient, check the mattress deck angle, bed height, and the state of the side-rails and boards.

- If a physician, nurse, or attendant will leave the bed area or take their eyes off the patient, set the mattress deck angle to zero (flat) and the bed height to the lowest position according to the condition of the patient in case of falling off the bed.
- If a patient cannot maintain a posture independently or has difficulty in walking, raise all side-rails. If you want to fill the gap between the Foot-end side-rail and footboard when using an extension frame, use a side-rail spacer/Foot spacer (PC-5112/IC-A33321Q (accessory), see p. 88).

■ Do not transport the bed with the patient on it while the head is raised using Cardiac Chair motion or the bed is inclined.

The patient may fall from the bed or be caught in a gap, resulting in injury.



WARNING

<Operating the bed>

■ Do not allow the bed to be operated by a person deemed incapable of understanding bed operation (a child aged 12 or under or a person with dementia).

- If a person deemed incapable of understanding the operation operates the side-rail integrated panel, patient control panel, handheld controller (standard or accessory), or BED Navi (accessory) by oneself, the body may get caught in the bed by mistake, resulting in unexpected injury.

If there is a possibility that such a person operates the side-rail integrated panel, patient control panel, handheld controller (standard or accessory), or BED Navi (accessory), use one of the following procedures to limit operation to prevent accidents caused by unintended operation.

- Set Overall lock-out on the side-rail integrated panel or BED Navi (accessory) to disable the operation of the side-rail integrated panel, patient control panel, handheld controller (standard or accessory), and BED Navi (accessory). (For the setting procedure, see p. 64 or the instruction manual for the BED Navi (accessory).)
 - Set Patient lock-out on the side-rail integrated panel or BED Navi (accessory) to disable the operation of the patient control panel and handheld controller. (For the setting procedure, see p. 64 or the instruction manual for the BED Navi (accessory).)
 - Set Selective lock-out on the BED Navi (accessory) to disable individual head/knee/height/inclining operations. (For the setting procedure, see the instruction manual for the BED Navi (accessory).)
 - Disconnect the power plug and turn the battery off.
- Note that resetting the settings on the BED Navi (accessory) enables all bed operations again even when the side-rail integrated panel, patient control panel, handheld controller (accessory), and BED Navi (accessory) operations have been disabled. The bed may move unexpectedly, resulting in injury. (See the instruction manual for the BED Navi (accessory).)

■ Use the bed in the correct orientation.



Lying down on the bed with the feet at the head end and the head at the foot end induces an unnatural posture during bed operation (mattress deck angle) which may result in injury.

■ Do not perform any angle adjustment when the patient is lying face down or on their side (in any posture other than lying face up).



There is a risk of injury caused by extending the joints backward.

1 BEFORE USING THE BED



WARNING

■ Do not perform bed operations such as raising the head or knee section with a restraint belt attached to the mattress deck.

- The patient's body may be squeezed resulting in injury or the bed may be damaged or deformed.
- If the patient or attendant operates the side-rail integrated panel, patient control panel, handheld controller (standard or accessory), or BED Navi (accessory), the body may get caught in the bed by mistake, resulting in unexpected injury. If there is a possibility that such a person operates the side-rail integrated panel, patient control panel, handheld controller (standard or accessory), or BED Navi (accessory), use one of the following procedures to limit operation to prevent accidents caused by unintended operation.
 - Set Overall lock-out on the side-rail integrated panel or BED Navi (accessory) to disable the operation of the side-rail integrated panel, patient control panel, handheld controller (standard or accessory), and BED Navi (accessory). (For the setting procedure, see p. 64 or the instruction manual for the BED Navi (accessory).)
 - Set Patient lock-out on the side-rail integrated panel or BED Navi (accessory) to disable the operation of the patient control panel and handheld controller. (For the setting procedure, see p. 64 or the instruction manual for the BED Navi (accessory).)
 - Set Selective lock-out on the BED Navi (accessory) to disable individual head/knee/height/inclining operations. (For the setting procedure, see the instruction manual for the BED Navi (accessory).)
 - Disconnect the power plug and turn the battery off.
- Note that resetting the settings on the BED Navi (accessory) enables all bed operations again even when the side-rail integrated panel, patient control panel, handheld controller (accessory), and BED Navi (accessory) operations have been disabled. The bed may move unexpectedly, resulting in injury. (See the instruction manual for the BED Navi (accessory).)

■ Use the bed according to the patient's medical condition.

- Depending on the patient's medical condition, the condition may become worse if the patient's posture is changed by operating the bed or raising the head or knees.
- If the patient or a family member operates the bed, make sure that the physician or nurse explains the details given in the instruction manual and usage suitable for the patient's medical condition.



WARNING

<Using the bed>

■ Use the bed with the boards attached, except when providing treatment. Also, check the patient's condition when detaching the board.

- A body part may get caught in a gap between the board and other objects, such as a suitable product or peripheral device, resulting in injury.
- The patient may fall off the bed, resulting in injury.

■ Do not use the bed for patients with a height of 146 cm or less, a weight of 40 kg or less, and a BMI of 17 or less.

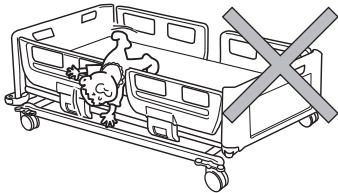

- This product is not designed for patients with a height of 146 cm or less, a weight of 40 kg or less, and a BMI of 17 or less. A part of the body may get caught in a gap between the bed and side-rail, resulting in injury.
- Even when the side-rails are used, an infant or small child may fall off the bed through a gap between the bed and side-rail, resulting in injury.

■ Do not stand on the bed.

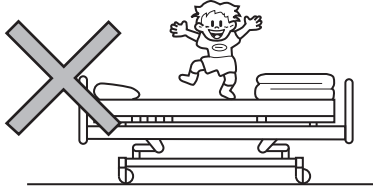

The patient may fall off the bed resulting in injury or the bed may be damaged or deformed. In particular, be careful with children.

■ Do not spill liquids on the bed.

- Do not spill liquids on the bed's electrical components, such as the connector^{*)}, side-rail integrated panel, and patient control panel. The bed may malfunction resulting in injury or may be damaged due to a short circuit.
 - If liquid is accidentally spilled on the bed, disconnect the power plug from the outlet and wipe off the liquid. Dry the bed completely and make sure that the bed operates safely before use.
- ^{*)} Connector to connect optional electrical components, such as a handheld controller, Nemuri SCAN, or nurse call relay unit

■ Do not place the bed in a strong electromagnetic environment such as an MRI.

- The bed may operate abnormally, resulting in injury or in damage to the bed.

1 BEFORE USING THE BED



WARNING

■ Do not attach the restraint belt to any location other than the restraint belt holder.

The restraint belt may unexpectedly come off resulting in injury, or the bed may be damaged or deformed.

■ The bed should be transferred by at least two persons.

- When transferring the bed, blind spots may occur in the direction of travel and the bed may collide with a person, resulting in injury. In addition, the bed may collide with an object and the bed and the object may be damaged or deformed.
- The person at the front should pay attention to the direction of travel and corners.

■ When using suitable products directly attached to the bed such as mattresses, use products suitable for the bed specified by Paramount Bed.

The use of products other than the specified ones or those from other companies may create unintended gaps, cause contact between products, or lower stability, resulting in injury or failure of the bed. (For suitable products, see p. 76.)

■ Keep the bed away from fire.

Do not use heating appliances such as heaters near the bed. This may cause deterioration, deformation, or fire.

■ Do not use the bed in the oxygen tent.

- Fire could result.
- When using oxygen administration devices, use nasal type, mask type, or artificial respirator type only.

■ When using flammable anesthetics, do not operate the bed.

Fire could result.

■ Be careful to prevent clothing from getting caught on suitable products and protrusions.

- If the bed is operated with clothing caught, the clothing may be pulled, resulting in injury.
- When getting on or off the bed, the patient may fall off the bed or fall down, resulting in injury.



WARNING

<Transferring and moving the bed>

■ **When transferring the bed, watch your step.**

Your leg may bump into the side pedal or your foot may get caught by a caster, resulting in injury.

■ **Lock casters at all times except when moving the bed.**

- When the patient gets into or out of the bed, the bed may move, resulting in unexpected injury.
- When moving the bed, operate the side pedal and unlock the casters. (See p. 33)

■ **Do not stand on the side pedal.**

There is a risk of injury due to falling or damage to the bed.

<Power plug and cables>

■ **Be careful not to trip over the power cable or handheld controller cable.**

- The power plug or cables may be damaged, resulting in electric shock or fire.
- You may fall over and injure yourself.

■ **Do not run cables (such as the power cable) of the bed or other electrical appliances under the bed.**

The cables may get caught in casters or moving parts and be damaged, resulting in electric shock or fire.

■ **Do not apply excessive force to the power plug.**

The power plug may be damaged, resulting in electric shock or fire.

1 BEFORE USING THE BED



WARNING

Do not allow dust to accumulate on the power plug.

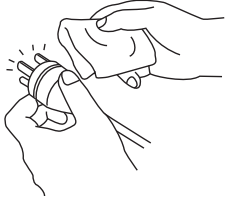

- Dust on the power plug can absorb moisture and conduct electricity, resulting in a short circuit, electric shock, or fire.
- Use a dry cloth to wipe away any dust that accumulates on the surface of the power plug.

Do not connect or disconnect the power plug with wet hands.

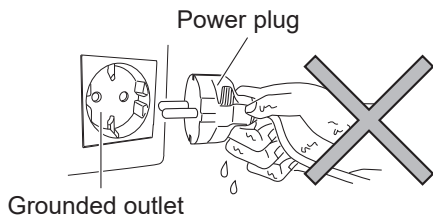

There is a risk of electric shock or failure due to a short circuit.

* The illustration shows a type C power plug.

When disconnecting the power plug, hold the power plug.

If you hold only the power cable when disconnecting the power plug, the cable may be damaged, resulting in electric shock or fire.

Be sure to disconnect the power plug and turn the battery off before performing maintenance.

The bed may operate due to unintended operation, resulting in injury.

Do not damage the cables (such as the power cable).

- The cables may be damaged, resulting in electric shock or fire.
 - Be careful to prevent cables from getting caught in the moving parts of the bed.
 - Do not place heavy objects on cables or apply excessive force to them.
 - Do not run over cables with the bed.
- Request repair (or replacement) of damaged cables.



WARNING

Take care when handling electrical components such as the side-rail integrated panel and BED Navi (accessory).

- The bed may malfunction resulting in injury or damage. In addition, a short circuit may cause electric shock or fire.
 - Do not hit or damage electrical components.
 - Do not drop electrical components, or forcefully pull their cables.
- Request repair (or replacement) of electrical components such as the side-rail integrated panel if they are damaged.

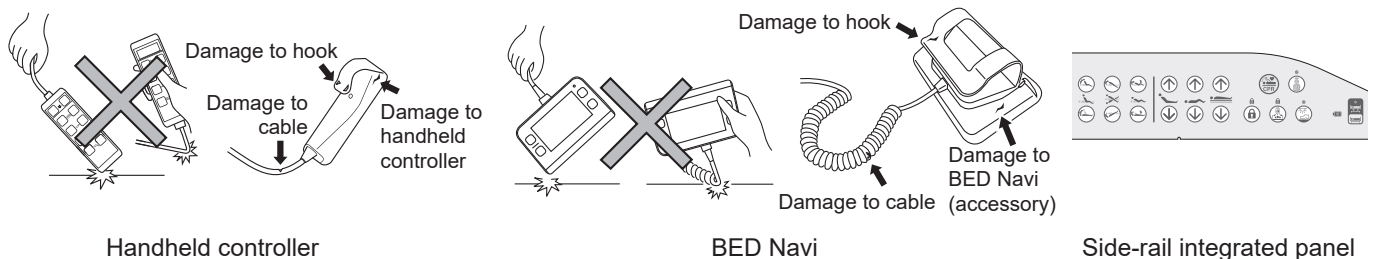

Handheld controller

BED Navi

Side-rail integrated panel

Do not apply a strong impact to the touch panel of the DS display panel and BED Navi (accessory) or touch it with a sharp object.

- Doing so may damage the touch panel, resulting in injury, electric shock, or malfunction.
- Do not touch the LCD liquid leaked from a broken touch panel.
 - If the liquid gets on your skin or clothing, wash it off with soap and water. In particular, if the liquid gets into your eyes, seek medical attention.

Disconnect the power plug from the outlet and turn the battery off when using electronic medical equipment.

- Using the bed at the same time with electronic medical equipment (e.g., microwave or ultrasonic medical equipment) may cause failure or malfunction.
- Check for safety before using the bed in conjunction with other medical equipment.

If you do not use the USB port, disconnect the cable from the USB port. Furthermore, do not operate the side-rail while the cable is inserted into the USB port.

You may accidentally injure yourself. The USB port, USB device, cable, etc. may also be damaged.

1 BEFORE USING THE BED



WARNING

<Maintenance>

■ **Do not repair or modify the bed or its components by yourself.**

This may create unintended gaps or may cause malfunction, resulting in injury.

■ **When operating the bed, pay attention to lines connected to the patient.**

- Lines may be pulled, resulting in injury, or the lines or devices may be damaged.
- Lines may be pinched by the bed, resulting in injury, or the lines or devices may be damaged.

■ **Inspect the bed regularly.**

The product wears out and deteriorates differently depending on the operating frequency and environment. Inspect for loose parts and damage and the operation of the moving parts regularly. The continued use of a product in a worn/deteriorated condition may result in unexpected injury. (See p. 104)

■ **Request inspection or repair of a damaged bed.**

If the bed is damaged in an earthquake, fire, flood, or any other incident, contact Paramount Bed (see p. 122) or your distributor for inspection or repair. Otherwise, there is a risk of electric shock or fire due to a short circuit or current leakage from electrical components, or injury due to malfunction caused by deformation of the bed.



WARNING

- **Do not disassemble the battery.**
- **Do not throw the battery into fire.**
- **Keep the battery away from fire.**
- **Do not charge the battery with a non-suitable bed.**
- **Do not use the battery with equipment other than suitable beds.**
- **Do not apply a strong impact to the battery.**
- **Do not recharge the battery unit or operate the bed with the bed upside down.**

Improper handling by ignoring the above instructions may cause personal injury or property damage due to fluid leakage, fire, explosion, electric shock, or case rupture.

- **If fluid leaks out of the battery and spills on your skin or clothing, immediately wash it off with copious amounts of water.**

- In particular, if the fluid gets into your eyes, rinse them with copious amounts of clean water and seek medical attention.
- Since the battery fluid is diluted sulphuric acid, contact with eyes may cause loss of sight and with skin may cause a burn injury.
- If fluid leaks out of the battery, replace it immediately with a new one.

- **Check regularly whether the bed can be battery-operated or whether the battery replacement time has been reached. Replace a battery that has reached the replacement time.**

- The continued use of a battery that has reached the replacement life may cause fluid to leak out of the battery, resulting in fire.
- The estimated replacement time of the battery is 2 to 3 years after purchase. If the indicator shows that the remaining power is low or insufficient (see p. 43) soon after starting bed operation, even though the battery was recharged for more than 24 hours, replace the battery.
 - * The battery life varies depending on the operating frequency and environment, and storage condition of the battery.
- For assistance with checking the battery life or replacing or recycling the battery, contact Paramount Bed (see p. 122) or your distributor.

- **When pressing the power ON/OFF button of the battery, be careful not to get caught in the moving parts of the bed.**

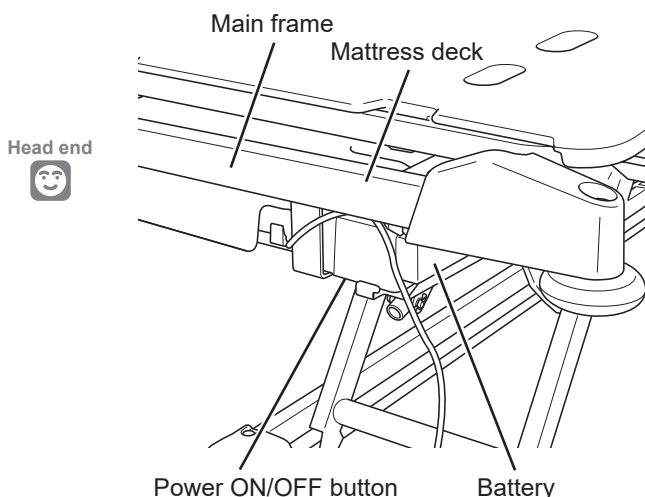

You may get caught in a gap between the mattress deck and main frame, resulting in injury.

* The illustration shows the bed with the headboard removed.

1 BEFORE USING THE BED

CAUTION

- **When adjusting the height or inclination angle, make sure that the bed does not hit a wall, beam, or power outlet on the wall.**

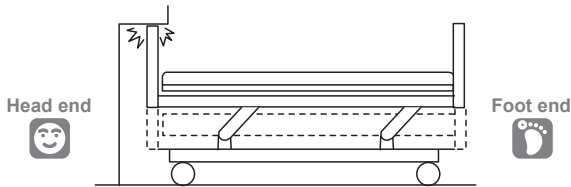

The bed, wall, or floor may be damaged or deformed. Make sure that the bed does not hit a wall, beam, or power plug during height or inclination angle adjustment.

- **When setting up the bed, allow at least 20 cm clearance from the wall.**

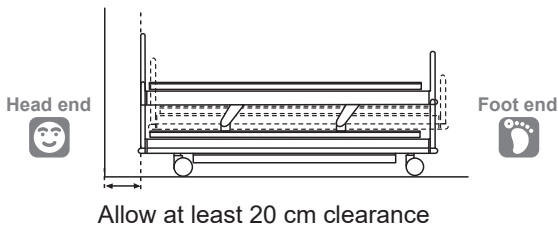

The main frame moves back and forth during inclination angle adjustment and may hit a wall, resulting in damage or deformation of the bed, wall, or floor.

- **Do not get on the mattress deck when it is raised.**

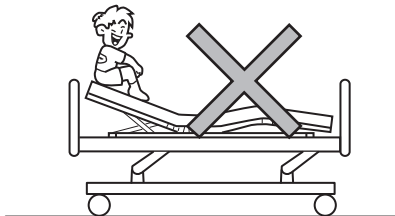

This applies excessive force to the support of the mattress deck, resulting in damage or deformation of the mattress deck.



CAUTION

■ The bed should not be used by two or more persons.

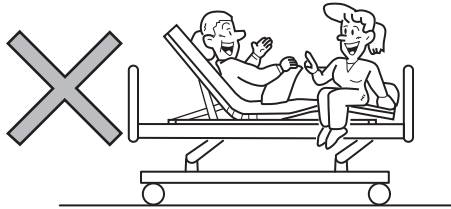

- This bed is designed for use by one person. If the bed is used by two or more persons, it may be damaged, resulting in injury. The maximum user weight allowed on the bed is 180 kg. If a physician, nurse, or caregiver needs to get on the bed for a short time, check the following points.
 - The total weight of the persons who will get on the bed must not exceed 180 kg.
 - The mattress deck has been lowered all the way and is horizontal (flat) at the lowest position.
- If a physician, nurse, or caregiver often gets on the bed, contact Paramount Bed (see p. 122) or your distributor for regular inspection of the bed.

■ Do not apply a load exceeding the safe working load on the bed.

The bed may be damaged or deformed, resulting in injury. The safe working load of this bed is 255 kg (2500 N). The safe working load is the maximum load with which the bed can be operated safely and is the total load of the user's weight and incidental items such as the mattress and suitable products.

■ Check around the bed before operating the bed.

Bed operation may damage objects around the bed, or may cause the bed to be damaged or deformed.

■ Make sure that the board stoppers of the headboard and footboard are locked.

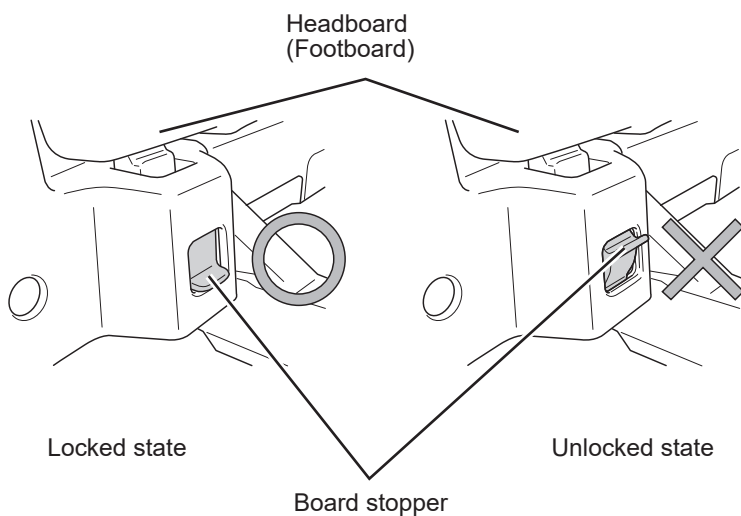

If the board is not attached properly, the board may suddenly disengage when the board is pushed or pulled to move the bed or the patient grabs the board to support their body, and the nurse or patient may lose their balance and fall down, resulting in injury. (See p. 28)

1 BEFORE USING THE BED



CAUTION

Do not move the bed while holding the side-rails.

This applies excessive force to the side-rails, resulting in damage or deformation of the side-rails.

Avoid moving the bed over uneven floors.

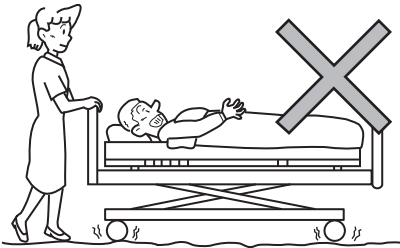

This may cause damage to the bed, or deformation or failure of the bed. If you must move the bed, move it as slowly as possible.

Attach a handheld controller (accessory) or BED Navi (accessory) suitable for the bed.

- If a handheld controller or BED Navi not suitable for the bed is attached by mistake, the bed may malfunction.
- A suitable handheld controller or BED Navi may be different among beds of the same series due to specification changes. Before attaching a handheld controller or BED Navi to the bed, check the model number and shape of the handheld controller or BED Navi to make sure that they are the same as those of the handheld controller or BED Navi suitable for the bed. (See p. 77 to 81)

Do not apply a spray-type insecticide directly to the bed.

The solvents contained in the insecticide may damage, discolor, or dissolve the casters or other resin parts of the bed. Furthermore, damaged or dissolved parts may cause accidental injury.

To avoid possible malfunctions, avoid installing in the following locations.

- Locations exposed to direct sunlight
- Locations exposed to cool or warm air from an air conditioner
- Locations exposed to excessive water or oil vapor
- Locations exposed to high temperature or humidity, low temperature, and dryness
- Locations with a large amount of dust, smoke, salt, sulfur, or corrosive substances
- Locations with poor ventilation
- Locations exposed to vibration and shock
- Locations where the floor is not flat
- Locations where the floor is not strong enough

3. Product symbol definitions

The following symbols are used for this product.

Bed

Symbol	Description
	Country of manufacture (Made in Indonesia) Manufacturing site * In the country of origin, the site acts as the manufacturer. Date of manufacture (YYYY-MM-DD)
	Manufacturer * It may be called "Legal Manufacturer" or "Brand Owner" etc. * This symbol is not applicable in the country of origin.
	Serial number
	Lot number
	Medical device (This product is a medical device or an accessory for medical device in Europe, and may be such a device in some countries and regions depending on their regulations. An accessory for medical device is required to be labeled as "Medical Device" under medical device regulations in Europe.)
	Model number
	Indicates products covered by the EU directive on waste electrical and electronic equipment (WEEE).
	Indoor use
	Refer to the instruction manual
	See the instruction manual
	KOHKIN SIAA mark
	This is a 2D Code (GS1 DataMatrix) that encodes the UDI (Unique Device Identifier) required by the Unique Device Identification System designed to adequately identify devices through distribution and use.
	Type B applied part
	Protective ground mark
	International protection code

Symbol	Description
	Safe working load
	Maximum user weight
	Product weight
	Maximum weight (Product weight + Safe working load)
	The medical bed for adults ≥40 kg ≥146 cm BMI≥17
	CPR lever
	Do not operate the bed with part of the body placed in a gap.
	Be careful not to get caught in the moving parts of the bed.
	Do not lean over a side-rail.
	Be careful not to get your head and neck caught in the gap of the side-rail.
	Side-rail stopper locked/unlocked status
	The side-rails should be operated by the nurse from outside the bed.
	Make sure that a mattress or other products used with the bed are suitable products designated by Paramount Bed.
	Four casters free
	Locking steering (straight forward movement)
	Four casters locked
	The lower limit setting position of the X-ray cassette. * When the cassette tray stopper is set at the lowest position

1 BEFORE USING THE BED

Side-rail integrated panel / Patient control panel

Symbol	Description
	Cardiac Chair motion up/down
	Head and knee coordinated up/down
	Trendelenburg/reverse Trendelenburg
	Head up/down
	Knee up/down

Symbol	Description
	Height up/down
	Electric CPR
	Nurse call
	Disable operation of the patient control panel and handheld controller (accessory)
	Disable all operations
	Foot light
	Battery status
	Not minimum height
	USB

Display panel

Symbol	Description
	Weight scale Press the button to display the weight scale measurement settings screen.
	Back
	Setting
	Error, warning, and caution

Symbol	Description
	Language
	Operation sound
	Mute operation sound
	Unmute operation
	Screen brightness

Symbol	Description
	Dark
	Normal

Symbol	Description
	Bright
	Screen off
	SCALE: Zero

Handheld controller (RC-1850E: accessory)

Symbol	Description
	Head and knee coordinated up/down
	Head up/down
	Knee up/down
	Height up/down
	Fast
	Operation sound
	Setting
	Date of manufacture (YYYY-MM-DD)
	Manufacturer * It may be called "Legal Manufacturer" or "Brand Owner" etc.
	Country of manufacture (Made in Japan)
	Model number

Symbol	Description
	Indicates products covered by the EU directive on waste electrical and electronic equipment (WEEE).
	This is a 2D Code (GS1 DataMatrix) that encodes the UDI (Unique Device Identifier) required by the Unique Device Identification System designed to adequately identify devices through distribution and use.
	Refer to the instruction manual.
	Serial number
	Lot number
	Medical device (This product is a medical device or an accessory for medical device in Europe, and may be such a device in some countries and regions depending on their regulations. An accessory for medical device is required to be labeled as "Medical Device" under medical device regulations in Europe.)
	CE mark
	Authorised representative in the european community * Either of the symbols is used.

Battery unit

Symbol	Description
	Power off
	Power on
	Indicates products covered by the EU directive on the Batteries Directive (2006/66/EC).

Symbol	Description
	Indicates products covered by the Act on the Promotion of Effective Utilization of Resources in Japan.
	Caution: Indicates that there are handling notes. Refer to the attached document.

1 BEFORE USING THE BED

4. Preparing the bed

Detaching the transport brackets

Before using the bed for the first time, detach the protective transport brackets attached to the bed.

- * 1 large transport bracket at the head end and 1 small transport bracket each on the left and right at the head end and the foot end.

Required tool

- * This tool is not supplied with the bed. Use your own tool.



Wrench (13 mm)



WARNING

Detach the transport brackets. If the notification function is set to **SIT-UP**, notification does not work properly and the patient may fall off or fall down, resulting in injury. In addition, when **SCALE** is used, correct measurements cannot be taken.

1. Insert the power plug into the outlet and raise the bed to a height at which it is easy for you to work.
See "Connecting to the power supply" on p. 40 and "Using the side-rail integrated panel" on p. 59 to 64.
2. Use a wrench (13 mm) to loosen the bolts (10 locations in total) and then remove the transport brackets.
 - * At the head end: Remove the small transport brackets first before removing the large one.

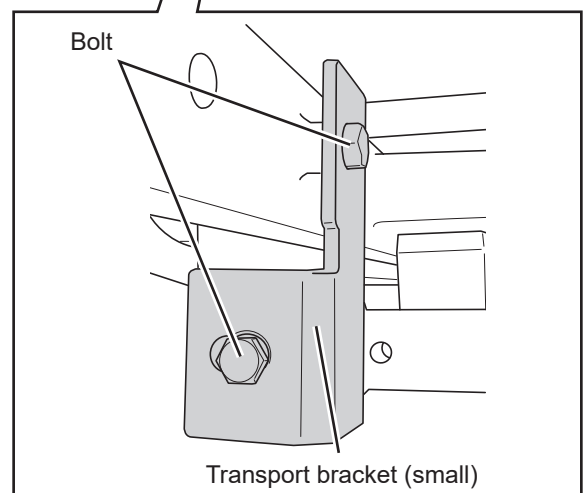
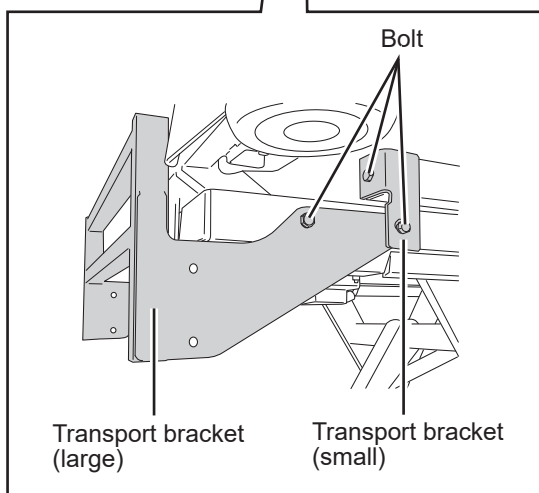
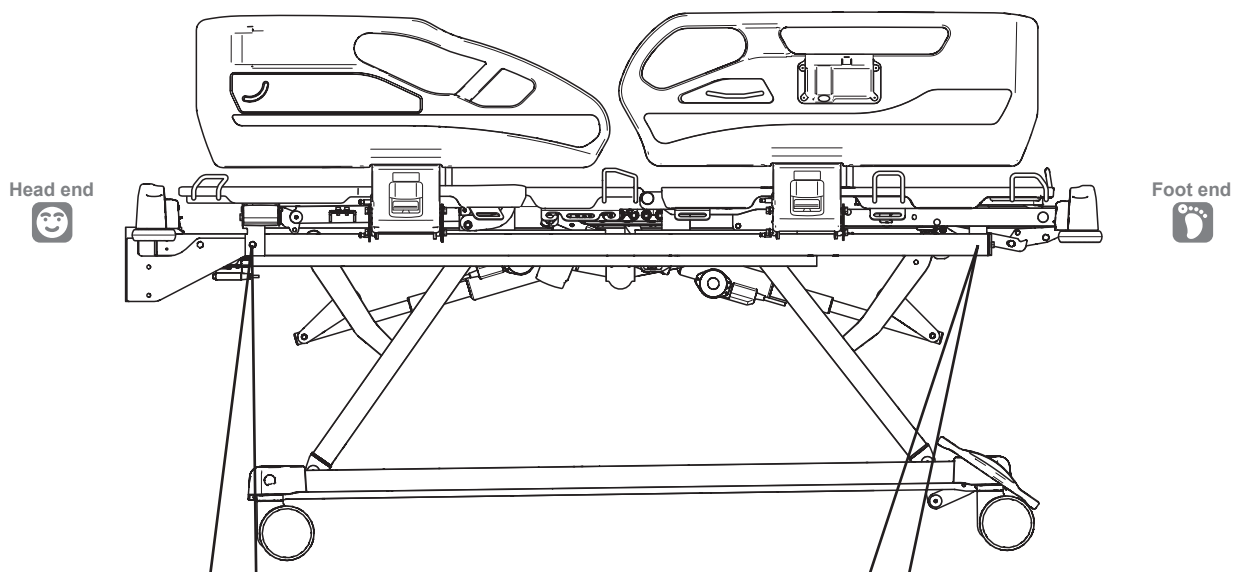

Attaching and detaching the headboard or footboard

The headboard and footboard can be attached and detached. When washing the patient's hair, detach the headboard. When performing lower limb training or giving a foot bath, detach the footboard.

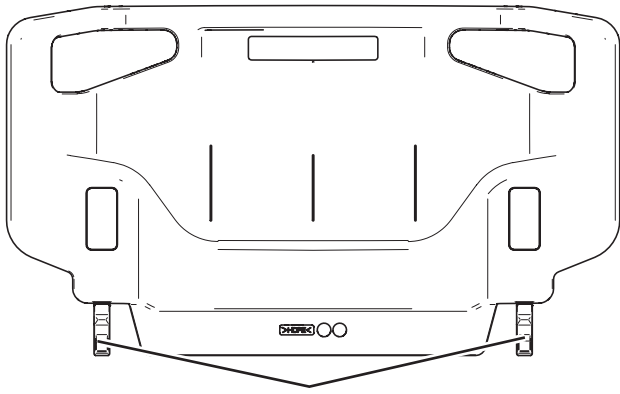

Board insertion part

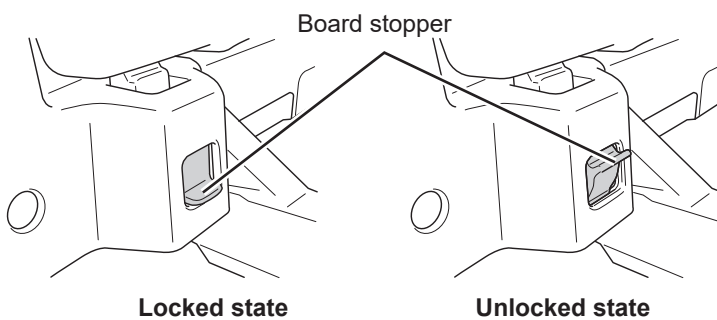

Locked state

Unlocked state

Board attachment hole

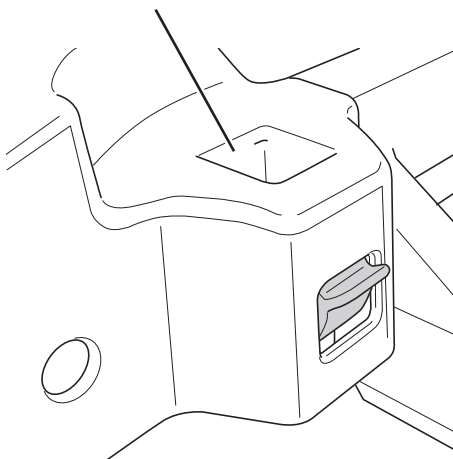

<Attaching>

1. Hold the grips of the headboard or footboard, lift up the board, and insert the board insertion parts into the board attachment holes securely until they click into place.
2. The board stoppers are automatically locked.



When attaching a board, insertion is possible regardless of whether the board stoppers are set to the unlocked or locked position.

<Detaching>

1. Set the board stoppers to the unlocked position. (2 locations)
2. You can detach the headboard or footboard by holding the grips of the headboard or footboard and pulling it straight up.



CAUTION

- When attaching the headboard or footboard, make sure that the board stoppers are locked. If they are not locked, the board may disengage when the bed is moved, resulting in injury due to a fall.
- When detaching the headboard or footboard, do not forcefully lift up the board while it is tilted. The board insertion part may be deformed.

1 BEFORE USING THE BED

Side-rail

- There are a total of 4 side-rails, 2 on the left and right, respectively.
- Side-rails prevent the patient from falling off the bed.

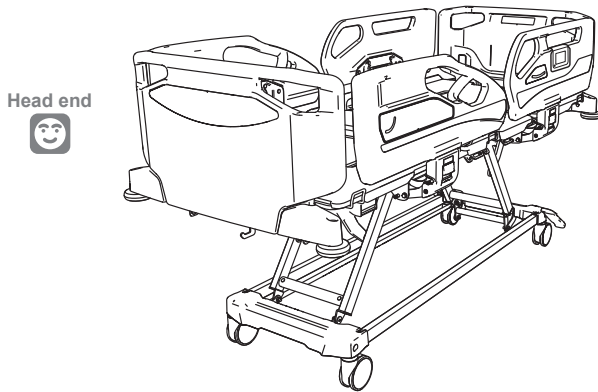

Raised state

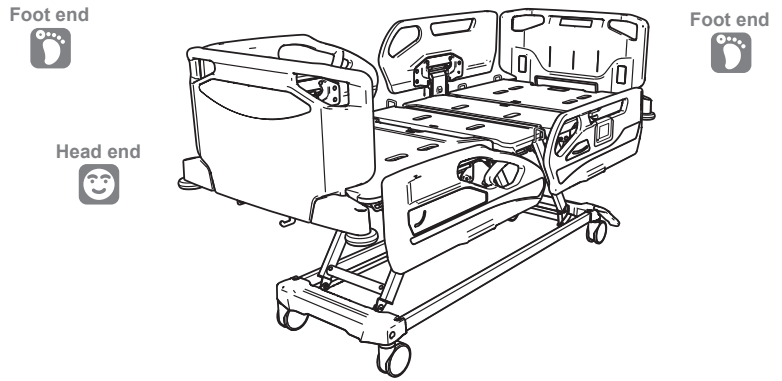

Lowered state



WARNING

- Be careful to prevent a body part (especially the head or neck) from entering a gap between the side-rail and mattress deck or mattress. If a body part is stuck in a gap, it may not be able to be pulled out, resulting in injury. Be especially careful to check a patient who might act in unexpected ways or cannot maintain their posture independently.
- The side-rails should be operated by the nurse from outside the bed. If the patient operates the side-rails from inside the bed, the side-rails may go down suddenly and the patient may fall off the bed, resulting in injury.
- Do not let the patient lean against a side-rail while it is raised. The patient may lose their balance and fall off the bed, resulting in injury.
- When a thick mattress is used, the effective height of the side-rails becomes lower. Be careful because this makes it easier for the patient to roll over them and fall, which may result in injury.
- Do not hang your legs over a side-rail while it is lowered. The bed may tip over, resulting in injury.
- When raising a side-rail, make sure that the lock is engaged. If the lock is not fully engaged, the side-rail may go down unexpectedly and the patient may fall off the bed, resulting in injury.
- Be careful to prevent lines from getting caught. When operating a side-rail, lines may get caught between the side-rail and mattress and be damaged, resulting in injury.
- When adjusting the height or inclination angle with the side-rail lowered, do not put your legs under the side-rail. They may get caught, resulting in injury.
- When operating a side-rail, make sure that the patient's hands or legs have not entered a gap between the side-rail and mattress deck. They may get caught in the gap, resulting in injury.
- Do not put your fingers in the moving parts of a side-rail. They may get caught, resulting in injury.
- Caution is required when operating a side-rail with the head section raised. If the head section angle is not proper, the side-rail may move unexpectedly, resulting in injury.

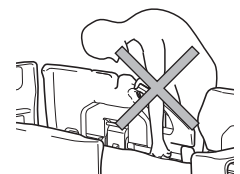
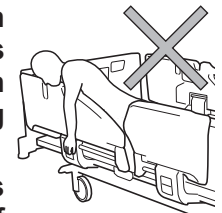

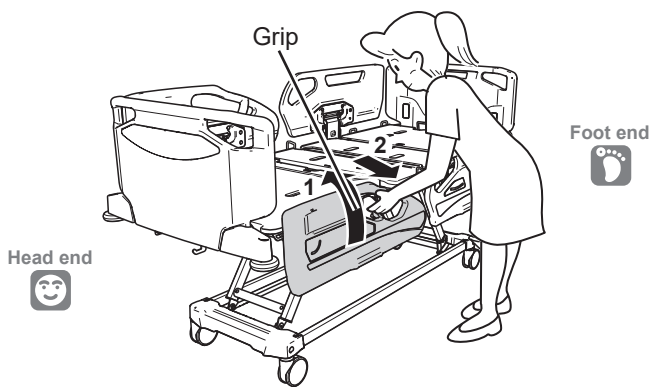

<Raising the side-rail>

1. Raise the side-rail and push in until it clicks into place.
2. Pull the side-rail toward you to make sure that the side-rail is locked.



<Lowering the side-rail>

1. Use one hand to hold the grip of the side-rail and push it to the back (toward the center of the bed).
2. While pushing it to the back, use the other hand to pull the operation lever toward you and, while supporting the side-rail, lower the side-rail until it stops.

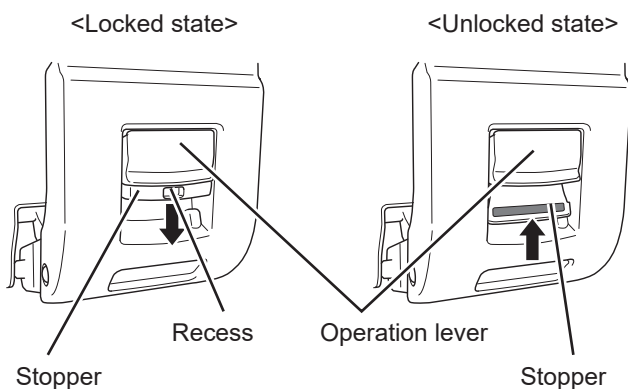

<Stopper>

Operation of the operation lever can be disabled by raising the stopper until the orange part cannot be seen.

1 BEFORE USING THE BED

Extension frame

The bed can be extended for tall patients by pulling out the extension frame and adding an extension mattress (accessory).



WARNING

When using the extension frame, use a suitable extension mattress (accessory: see p. 87). A body part may get caught in a gap between the bed and extension frame or side-rail, resulting in injury.

Frame stopper

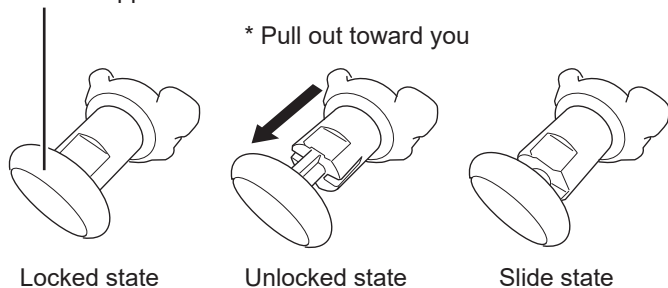

<Pulling out the extension frame>

1. Pull the frame stoppers attached to the left and right of the bed toward you and turn them either clockwise or counterclockwise to unlock.

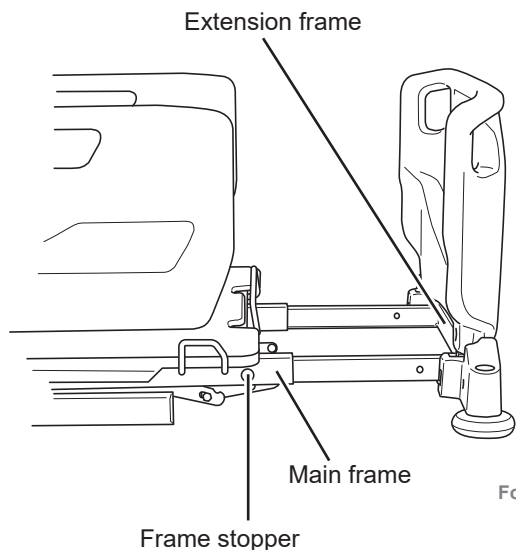

2. Hold the extension frame and pull it toward you a little.

3. Turn the frame stoppers to the locked position and set them to the slide state (half-engaged state).

4. Hold the extension frame again and pull it toward you until there is a click and the frame stoppers become locked in place.

5. Lightly push the extension frame to make sure that it is securely locked.

6. Refer to the instruction manual of the extension mattress (accessory) and then attach the extension mattress.

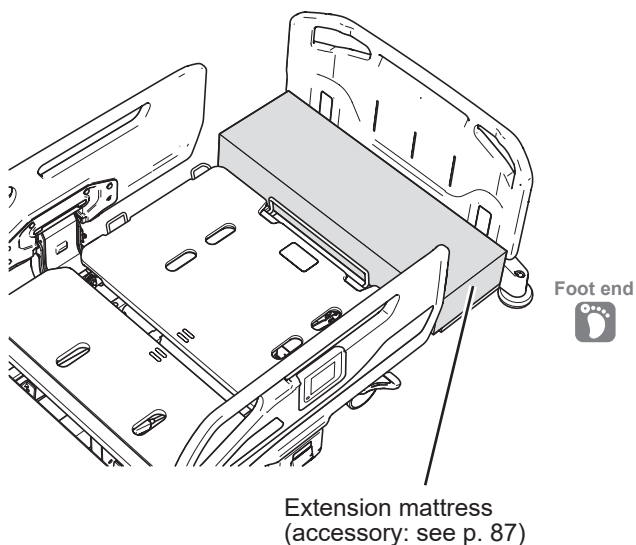

<Storing the extension frame>

1. Detach the extension mattress (accessory).
2. Pull the frame stoppers on both sides of the bed toward you and turn them either clockwise or counterclockwise to unlock. (See p. 31)
3. Hold the extension frame and push the extension frame back a little.
4. Turn the frame stoppers to the locked position and then set them to the slide state (half-engaged state).
5. Hold the extension frame again and push it until there is a click and the frame stoppers become locked in place.
6. Lightly pull the extension frame to make sure that it is securely locked.



WARNING

Do not put your hand, foot, or knee on the edge of the extension mattress (accessory). Since there is no support, you may lose your balance and fall over, resulting in injury.



CAUTION

- **When storing the extension frame, do not put your arms or legs between the bed and extension frame. They may get caught, resulting in injury.**
- **Securely lock the frame stoppers (see p. 31). The extension frame may come out unexpectedly during bed operation or transfer, resulting in injury.**

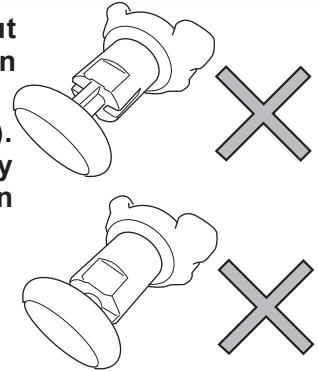

1 BEFORE USING THE BED

Locking casters

Casters can be locked with side pedals on the left and right of the foot end.



WARNING

Lock casters at all times except when moving the bed. When the patient gets into or out of the bed, the bed may move unexpectedly, resulting in injury.



CAUTION

- When locking the casters, be careful to prevent your foot from getting caught in a gap between the side pedal and floor. You may accidentally injure yourself.
- Do not forcibly move the bed when the casters are locked. The bed may break or the casters may damage the floor.

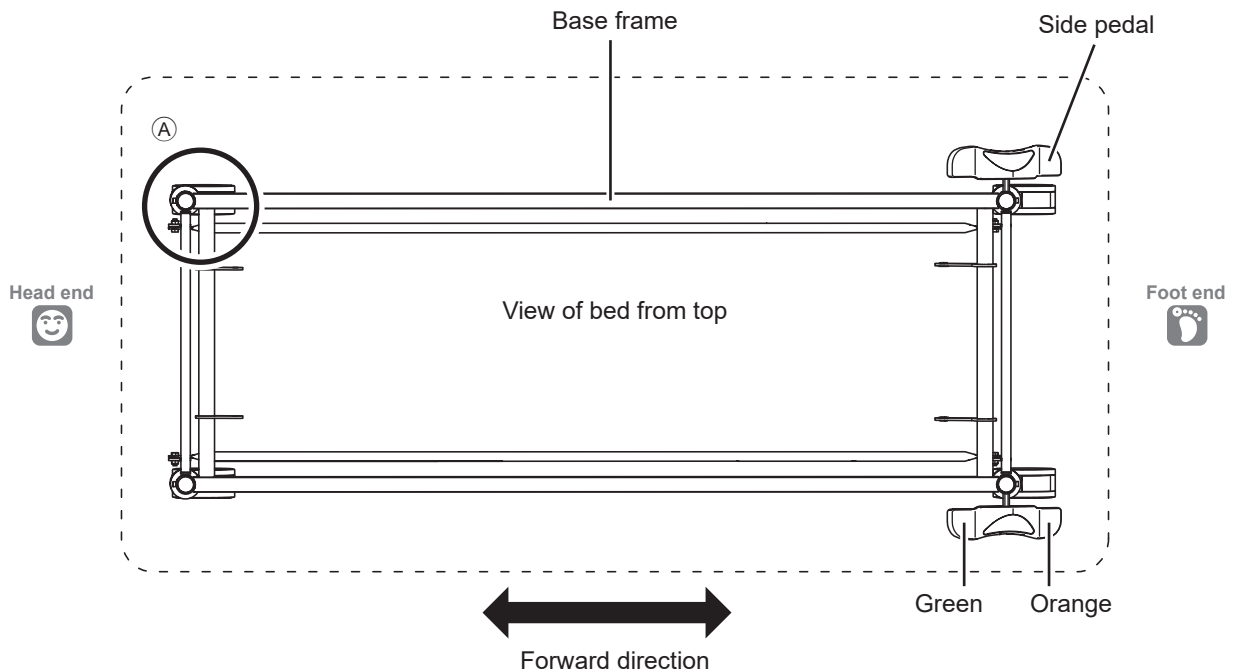

Locking 4 casters
Push down the orange side of the pedal to lock the swivel and rotation of all 4 casters.

Unlocking 4 casters
Return the pedal to the horizontal position to unlock the swivel and rotation of all 4 casters.

Locking steering (straight forward movement)
Step on the green pedal to lock swiveling of caster (A) in the straight forward movement direction. This helps the bed to be transferred straight forward easier.

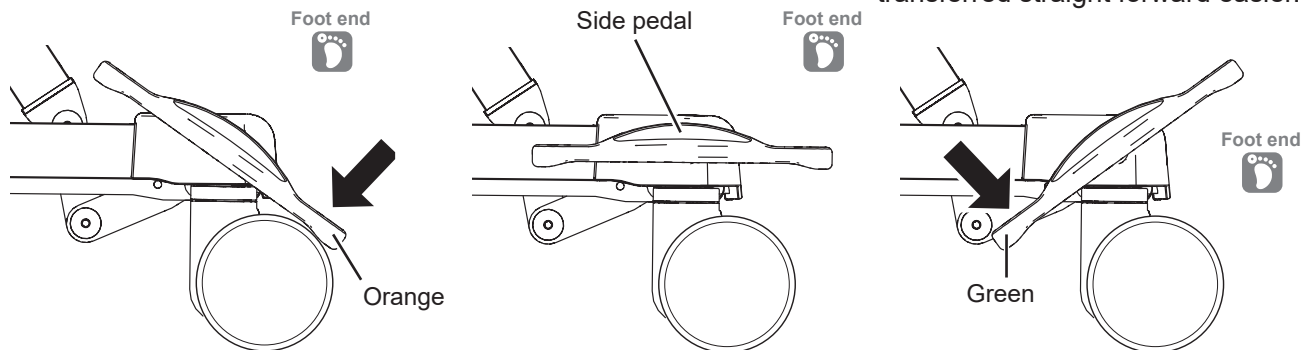

Inspect the casters regularly. Casters wear out and deteriorate depending on the operating frequency and environment (deterioration may be accelerated in a high temperature and humidity environment). If the performance of the stopper deteriorates or wheels are discolored or cracked, contact Paramount Bed (see p. 122) or your distributor for after-sales services, such as repair.

Raising the foot end

You can change the angle of the leg section so that the foot end is raised.

[Foot end lowered state]

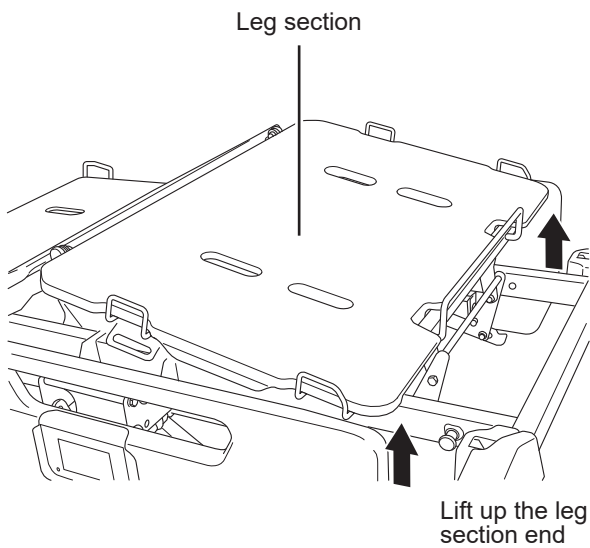
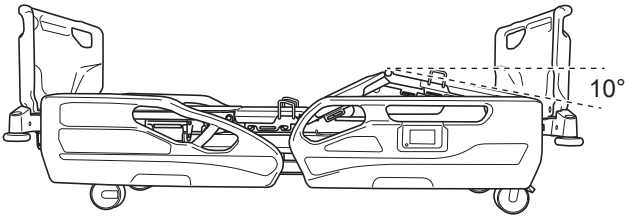

<Switching method>

1. Perform the knee up operation to raise the knee section.
2. Holding both ends of the leg section, lift up the leg section all the way.
The leg section switching lever locks and the foot end will be in the raised state.
3. To lower the foot end, lift up the leg section switching lever with one hand while supporting the leg section end with your other hand, and lower the leg section slowly.

* You can also lower the foot end by performing the knee lowering operation while the foot end is raised to lower the knee section to the lower limit.



When the knee up operation is performed again after lowering the knee section all the way to the bottom, the foot end will be in the lowered state.

[Foot end raised state]

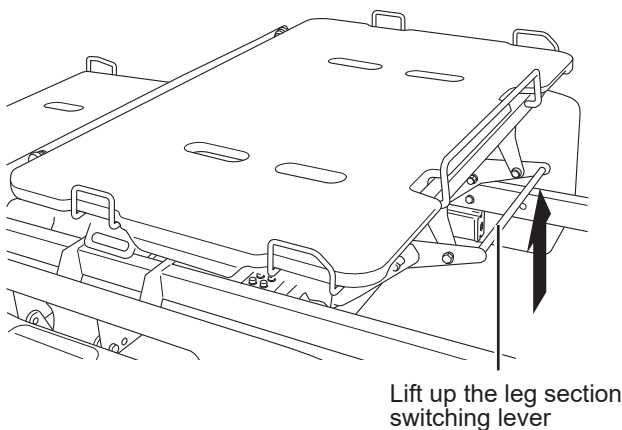
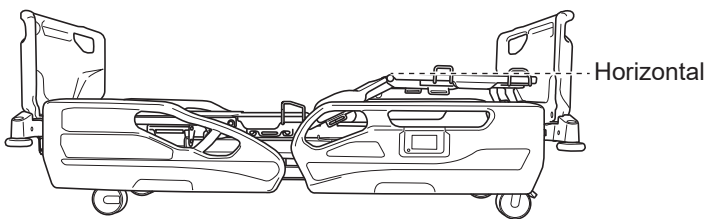

1 BEFORE USING THE BED

Accessory rail

Accessory rails are in the locations shown below on the right and left sides of the bed. These rails can be used to hang accessories such as drainage bags.

- Two each on the left and right sides of the hip section (4 locations in total)
- One each on the left and right long sides of the main frame (below the knee section) (2 locations in total)



CAUTION

Do not apply a load of 3 kg or more to an accessory rail. This may damage or deform the accessory rail.

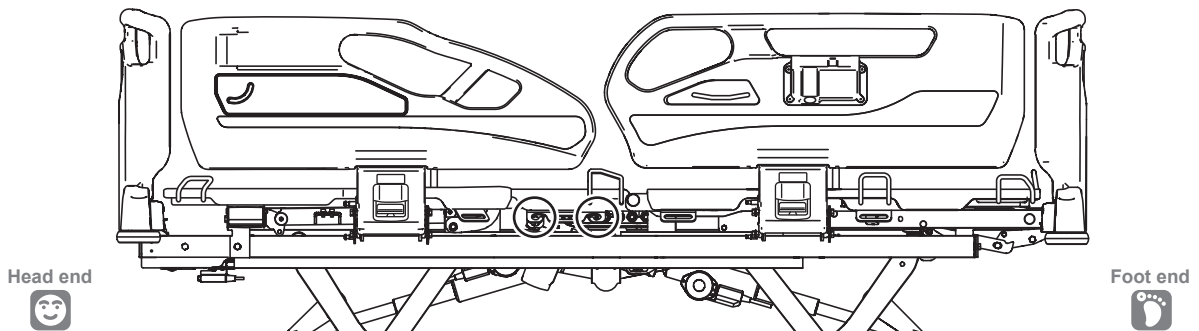

* There is no impact on weight measurement.

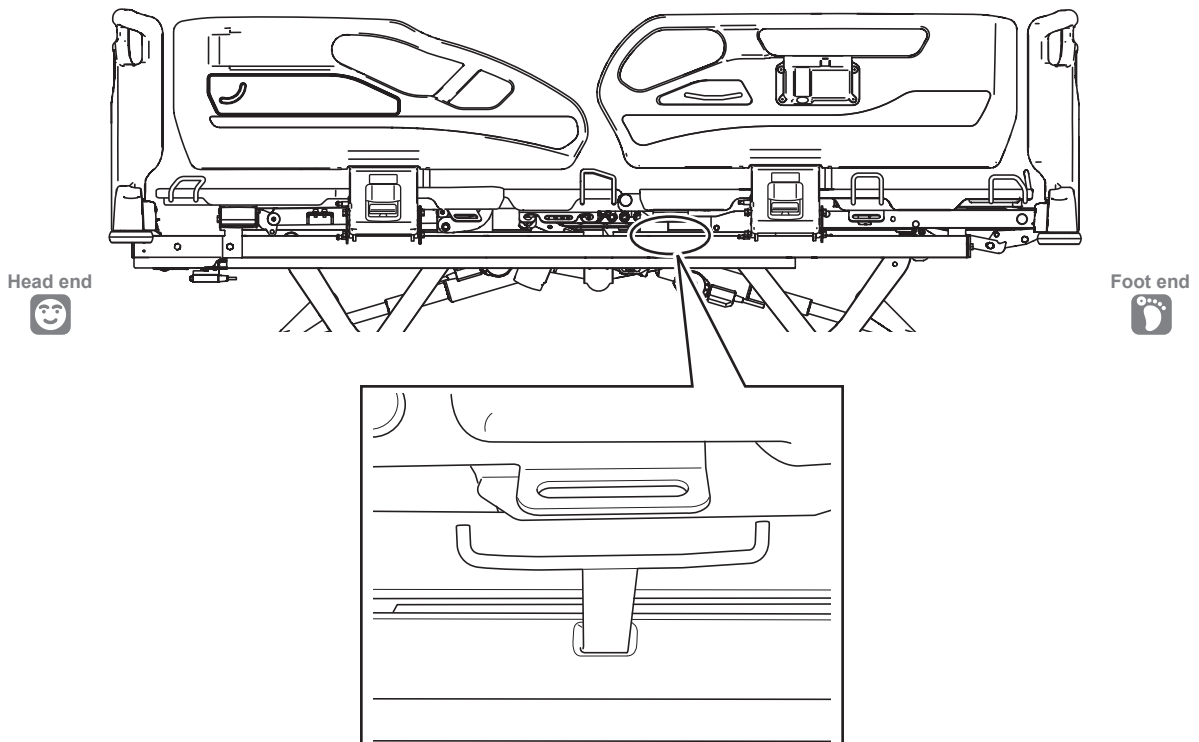

- Since the attachment method and dimensions of commercial drainage bags differ by manufacturer, use those suitable for the bed.
- When hanging a drainage bag, take care to prevent the bag or tube from getting caught when operating the bed or side-rail.
- When hanging a drainage bag, take care to prevent the bag from coming into contact with the floor.

Restraint belt holder

When fastening restraint belts, fasten them in the locations in the figure below.
The restraint belt holder can also be used as an accessory holder.



WARNING

Do not operate the bed with restraint belts fastened. The restraint belts may apply pressure to the patient, resulting in injury.



CAUTION

When making a bed or getting into or out of the bed, be careful not to put your hand or fingers in the hole of a restraint belt holder by mistake. There is a risk of injury.

Restraint belt holders on the mattress deck side (on the left and right of the mattress deck)

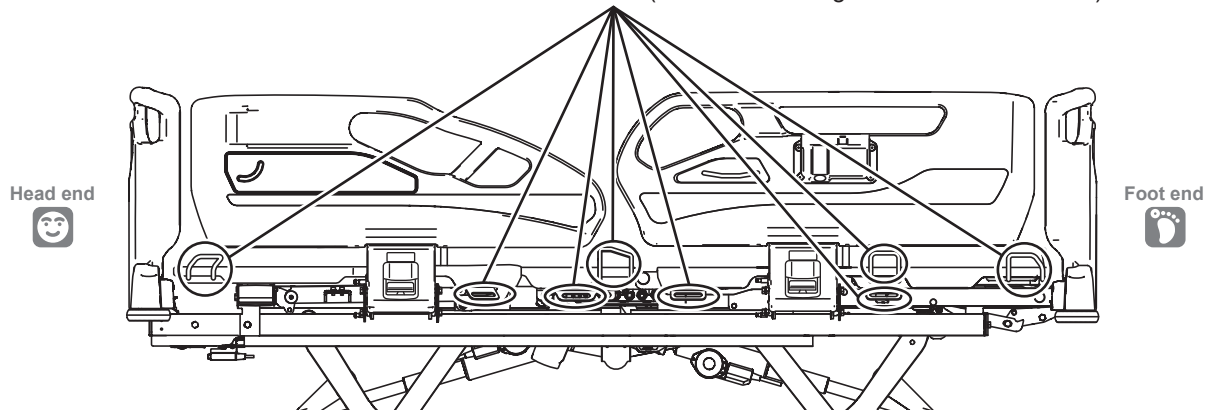

1 BEFORE USING THE BED

Accessory attachment hole

Accessory attachment holes are located at the head end and foot end of the bed in a total of 4 locations. They can be used to attach suitable products such as an IV pole and oxygen cylinder holder.

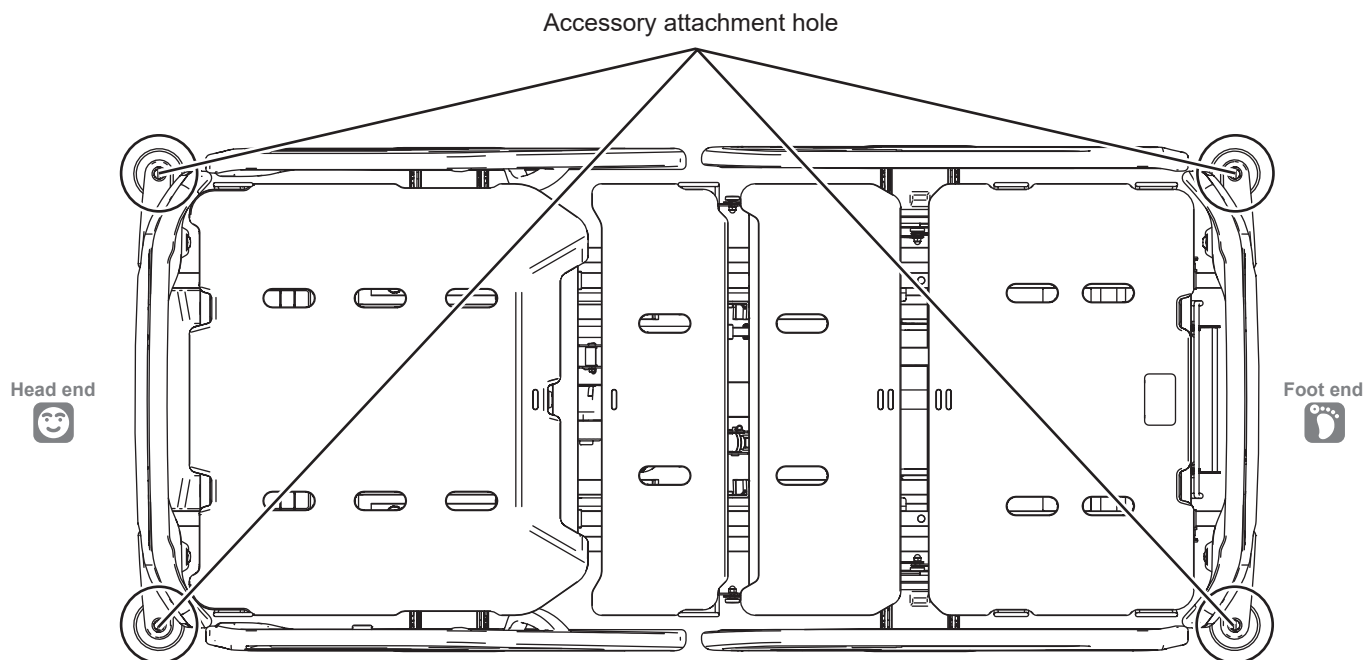

- Note that changing the inclination angle of the bed changes the inclination angle of suitable products inserted into the Accessory attachment holes.
- The Accessory attachment hole at the head end (1 each on the left and right) does not impact the weight measurement.

Roller bumper

Roller bumpers are attached to the 4 corners of the bed. When the bed is moved, they can absorb any impact that occurs when the bed hits a wall or equipment.

Head end

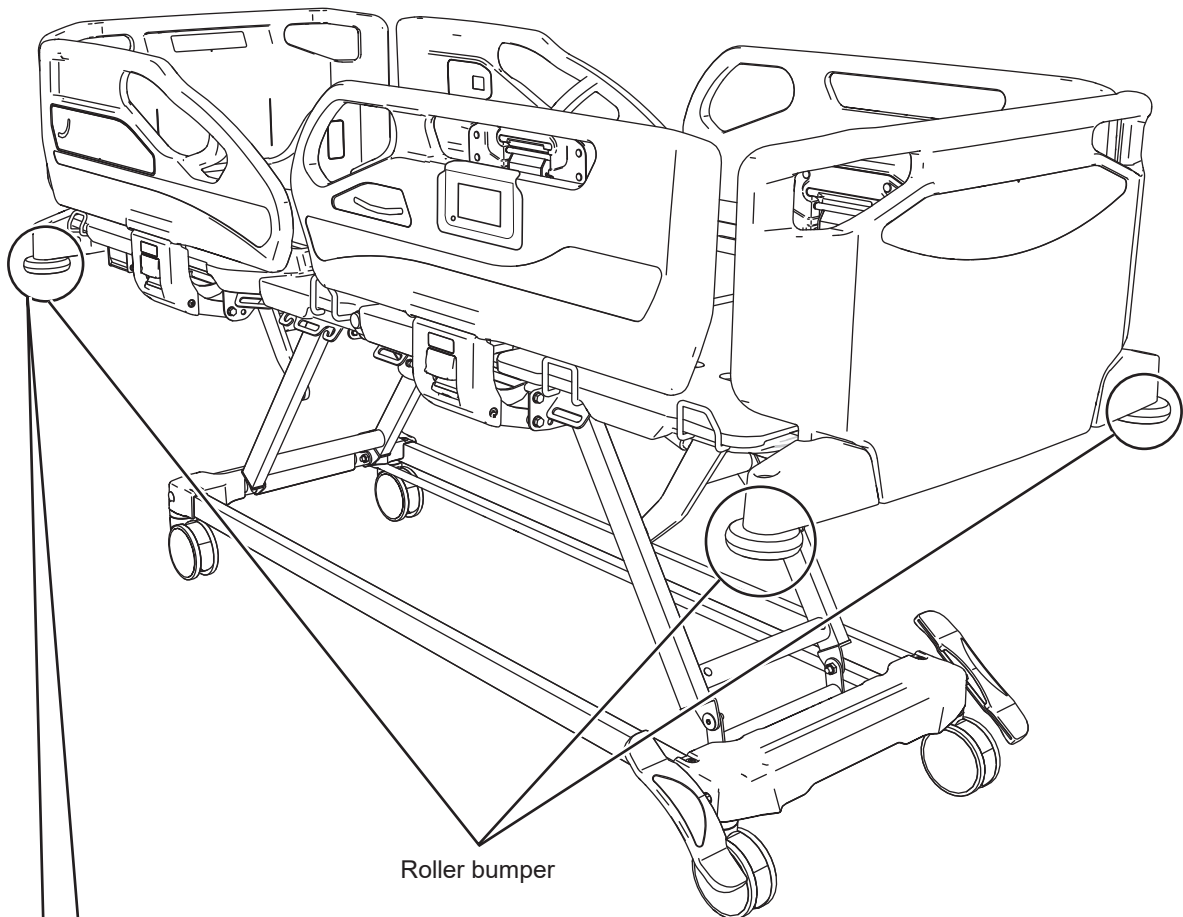

Foot end



Roller bumper

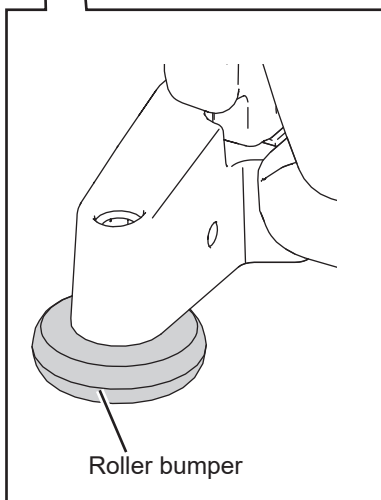

Roller bumper

1 BEFORE USING THE BED

Angle indicator

A head angle indicator is located on the outside of the Head-end side-rail and an inclination angle indicator is located on the outside of the Foot-end side-rail. The head angle and inclination angle can be checked respectively.

* The indicated angle values should be used as approximations.

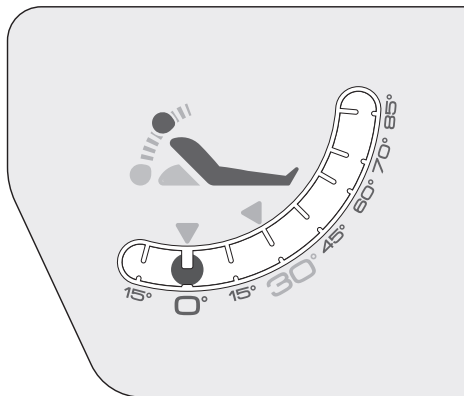
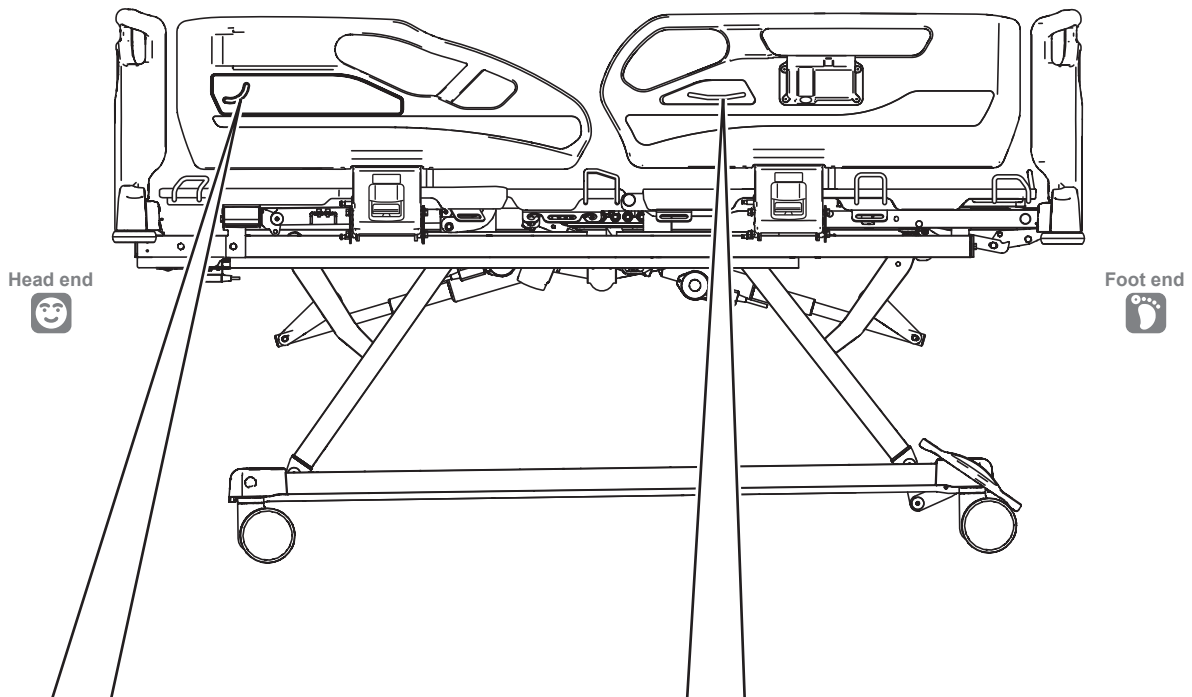

Head angle indicator

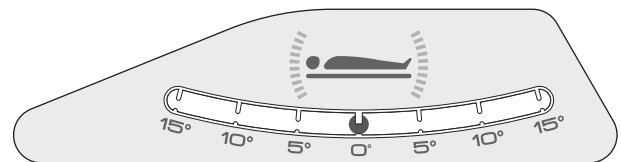

Inclination angle indicator

Connecting to the power supply



WARNING

Do not connect multiple cables to a single outlet. If other electrical equipment is plugged into the same outlet and the rated capacity of the outlet or extension cable is exceeded, the power cable and plug may overheat and cause fire.

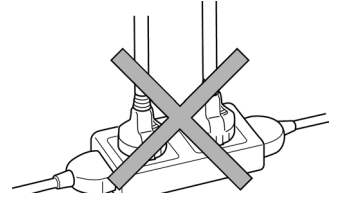

<Outlet>

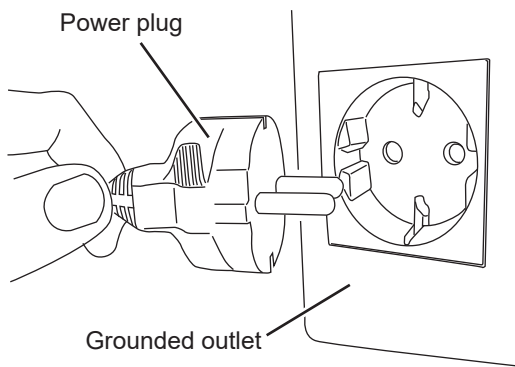

- Use a properly wired grounded outlet for each bed that meets the power consumption requirements of the bed. Also, firmly insert the power plug into the outlet.
- When installing the bed, place it where connecting and disconnecting the power plug will not be blocked.
- After use, disconnect the power plug from the outlet. For a model with a battery unit, also turn the battery off.

* The illustration uses a type C power plug for explanation.

<Using the cable storage hooks>

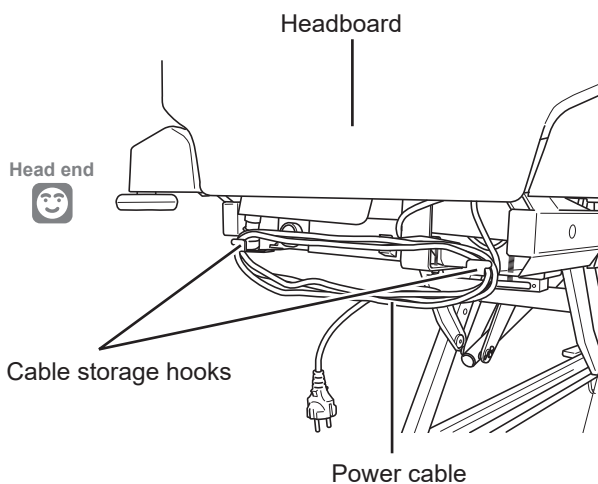

Wind the power cable around the cable storage hooks before moving the bed.

1 BEFORE USING THE BED

Battery unit

<Part names>

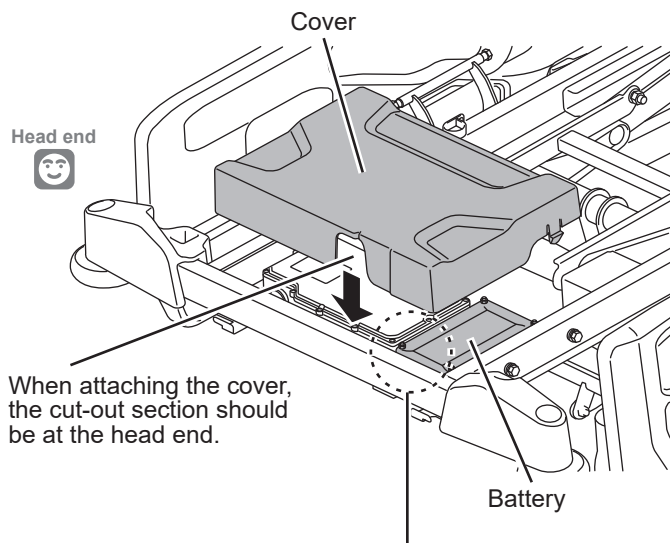

The battery is located under the main frame at the head end of the bed.



When replacing the battery, remove the cover. When attaching the cover, pay attention to its orientation.

* The illustration shows the bed with the head section raised and the headboard and cover removed.

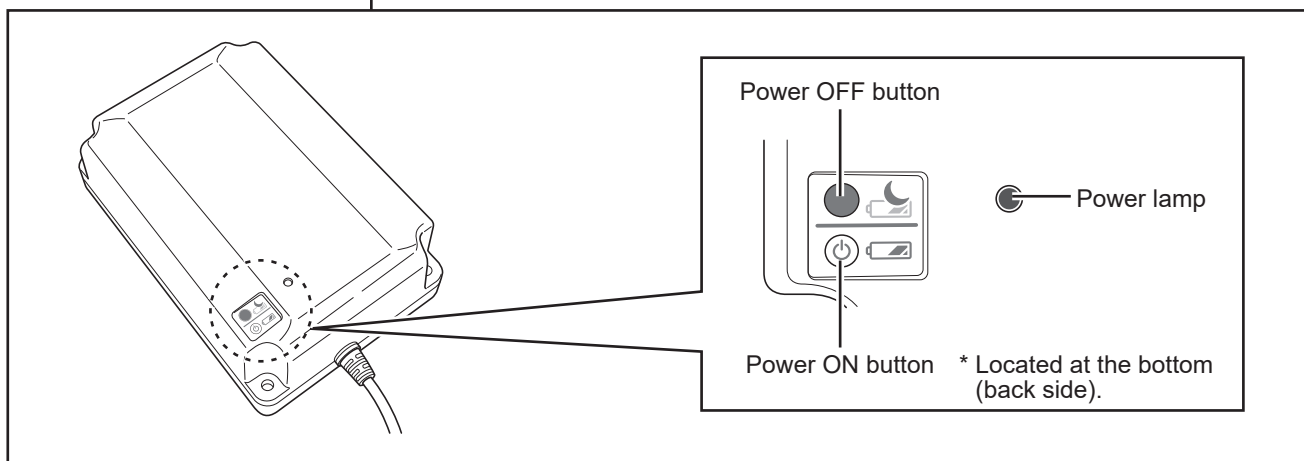

Power ON button (hold down for 4 seconds) : Enables battery-powered operation. When using the bed for the first time or using it after storage, press the power ON button. When the power turns on, the power lamp flashes.

Power OFF button (hold down for 1 second) : Disables battery-powered operation. When storing the bed, press the power OFF button to turn off the power.



- By default, the power is off. Inserting the power plug into the outlet automatically turns the power supply on.
- When the power is turned on, the power remains on even if the power plug is inserted into or disconnected from the outlet. To stop battery-powered operation, press the power OFF button.
- If the battery has been over-discharged, the power supply automatically turns off.

<Battery-powered bed operation>

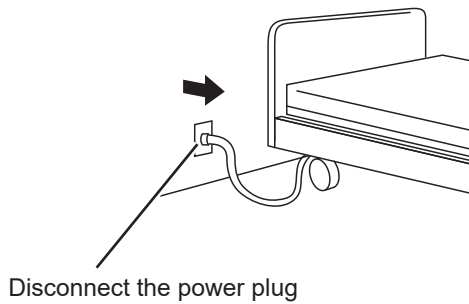

When the battery power is on, the bed can be operated by power from the battery while the power plug is not inserted into the outlet (or in the event of a power failure).



CAUTION

Do not operate the bed electrically during the emergency head down operation with the CPR lever of the bed. This may damage the motor.







- When the remaining battery power is sufficient (after recharging for 24 hours), three up-and-down movements can be performed for height adjustment while the safe working load is applied on the bed (at an ambient temperature of 25°C). However, the number of up-and-down movements varies depending on the operating frequency and environment, and storage condition of the battery.
- BED SPEED is slower than when operating the bed while the power plug is inserted into the outlet (except in the event of a power failure). In addition, the speed varies depending on the remaining power, operating frequency and environment, and storage condition of the battery.
- If battery-powered operation of the bed is not possible, check the battery status (see p. 43).

1 BEFORE USING THE BED

<Checking the battery status>

The battery status is displayed as shown in the table below.

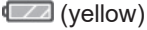
Power status	Battery status indicator lamp on the side-rail integrated panel	Power lamp on the DS display panel / BED Navi (accessory) / handheld controller (accessory)*)	Battery status indication on the BED Navi (accessory)	Battery status
The power plug is not inserted into the outlet or power failure is occurring	Lights in green		 (blue)	Remaining battery power is sufficient.
	Flashes green (on for 2 seconds → off for 2 seconds)		 (blue)	Remaining battery power is low. Since bed operation may become impossible, stop using and recharge the battery immediately.
	Flashes green (on for 0.1 seconds → off for 3.9 seconds)		 (blue)	Remaining battery power is insufficient. Buttons on the side-rail integrated panel, BED Navi (accessory), and handheld controller (accessory) do not work. Recharge the battery immediately.
The power plug is inserted into the outlet	Flashes green (on for 3.9 seconds → off for 0.1 seconds)			Battery is being recharged.
	Lights in green		 (yellow)	Battery recharging is completed.

*) If an error occurs, the error status is displayed (flashes orange) preferentially.



To extend the battery life, recharge the battery as frequently as possible before the indicator shows that the remaining power is low or insufficient (see the table above).



Side-rail integrated panel

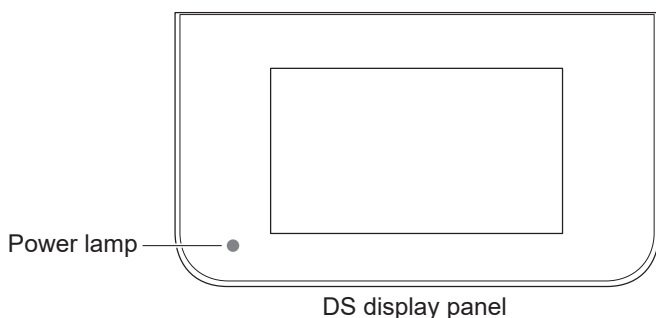

Power lamp

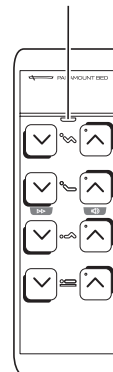

Handheld controller (accessory)

<Recharging the battery>

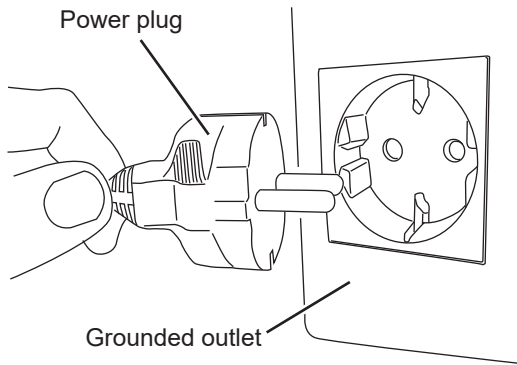

Inserting the power plug of the bed into the outlet starts recharging of the battery, and recharging will complete automatically after 24 hours. The battery can be recharged regardless of whether the power is on or off.

When using the bed for the first time, recharge the battery before use.



- Normally use the bed with the power plug of the bed inserted into the outlet and the battery recharged.
- Repeated recharging after the battery power is used up results in early degradation of maximum capacity and a shorter life span. After battery-powered operation of the bed, recharge the battery when possible.
- If the indicator shows that the remaining power is low or insufficient (see p. 43) soon after starting bed operation, even though the recharge is completed, it is time to replace the battery.

<Handling the battery>

■ Life

The battery life varies depending on the operating frequency and environment, and storage condition of the battery. Some batteries reach the end of their life in 2 to 3 years and almost all batteries reach the end of their life in 5 years, regardless of whether or not they are used.



- If the indicator shows that the remaining power is low or insufficient (see p. 43) soon after starting bed operation, even though the recharge is completed, it is time to replace the battery.
- Check regularly whether the bed can be battery-operated or whether the battery replacement time has been reached. Replace a battery that has reached the replacement time.

■ Operating environment

It is recommended to use the battery at around 25°C. The performance of the battery varies depending on the ambient temperature and deteriorates to 85% at 0°C compared to the performance at 25°C.

■ Storage

The battery self-discharges slightly even when the battery is powered off. When storing the bed, recharge the battery for 24 hours or more, disconnect the power plug of the bed, and power off the battery. This reduces the impact of excessive discharge on the life. Note that it is recommended to store the bed at an ambient temperature of 25°C.

When storing the bed for a long period of time, recharge the battery for 24 hours or more once every 3 months. If the battery is not recharged, the battery capacity may deteriorate or the battery may become no longer rechargeable. Recharging the battery automatically turns the power supply on. When storing the bed again, power off the battery.

1 BEFORE USING THE BED

Attaching and detaching the handheld controller (RC-1850E: accessory)

A handheld controller can be attached to this bed.

* For details on the handheld controller, see p. 77 to 81.



WARNING

- Select a suitable combination of the bed and handheld controller. If the combination is not suitable, the bed could move unexpectedly, resulting in injury or bed failure. (For the model numbers and shapes of the handheld controller, see p. 77 to 81.)
- Disconnect the power plug of the bed from the outlet and turn the battery off before attaching the handheld controller to the bed. If the handheld controller is inserted into the bed while the bed is plugged into the outlet, the bed could move unexpectedly, resulting in injury or bed failure.

There are handheld controller power outlets located one each on the foot end and on the left and right at the center of the bed main frame.

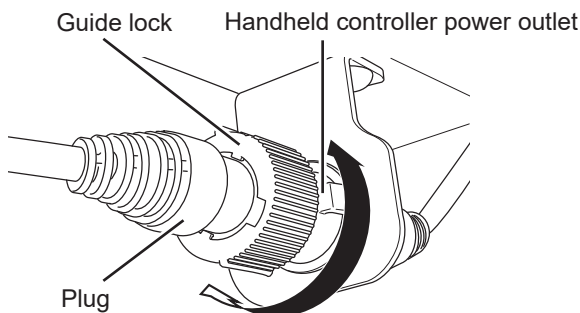
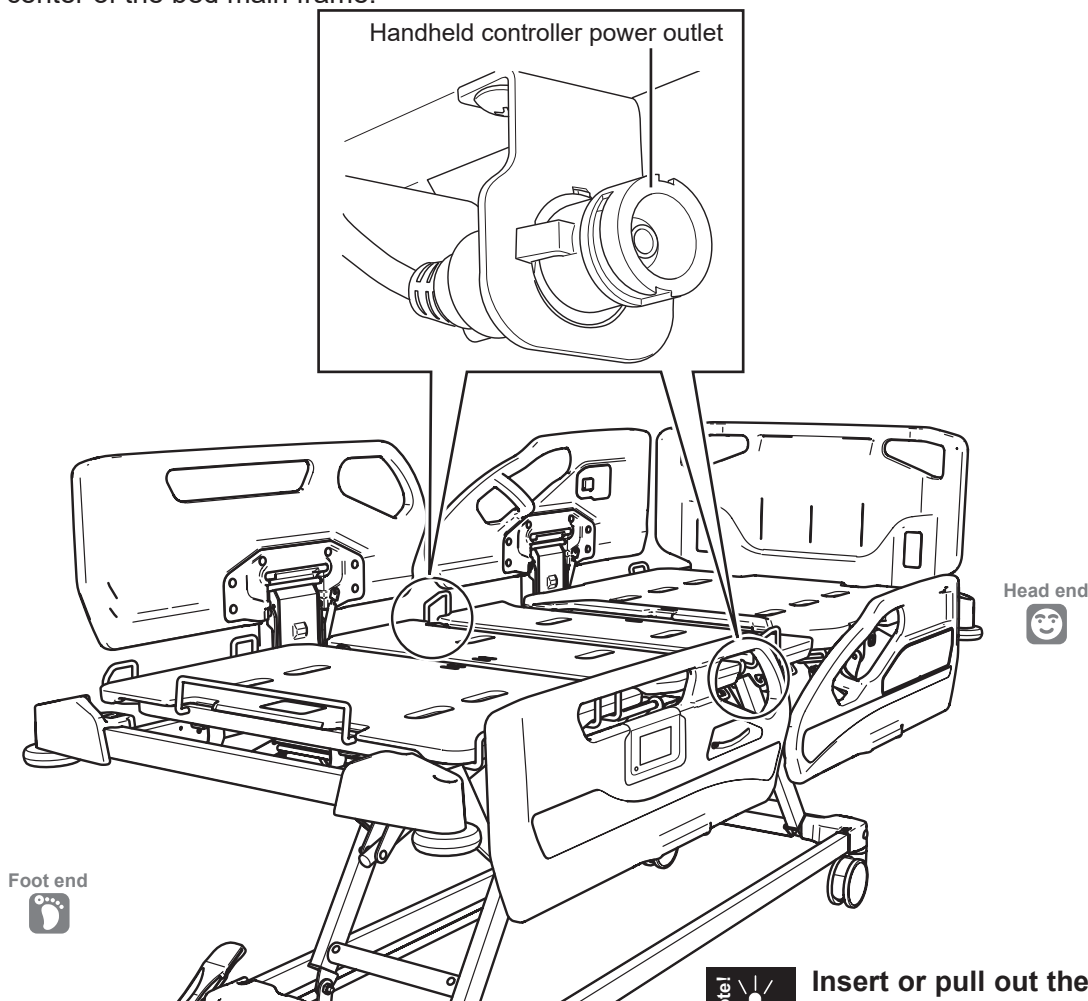

Note! Insert or pull out the handheld controller straight.

<Attaching>

1. Insert the plug into the handheld controller power outlet.
2. To prevent the plug from being disconnected, turn the guide lock clockwise to lock.

<Detaching>

1. Turn the guide lock counterclockwise to unlock.
2. Pull out the plug.

Handheld controller hook

The handheld controller (RC-1850E) has a hook. When not using the handheld controller, hook it on the top of the Head-end side-rail.

Make sure that the operation buttons of the handheld controller face out in order to prevent them from being pressed by the patient.

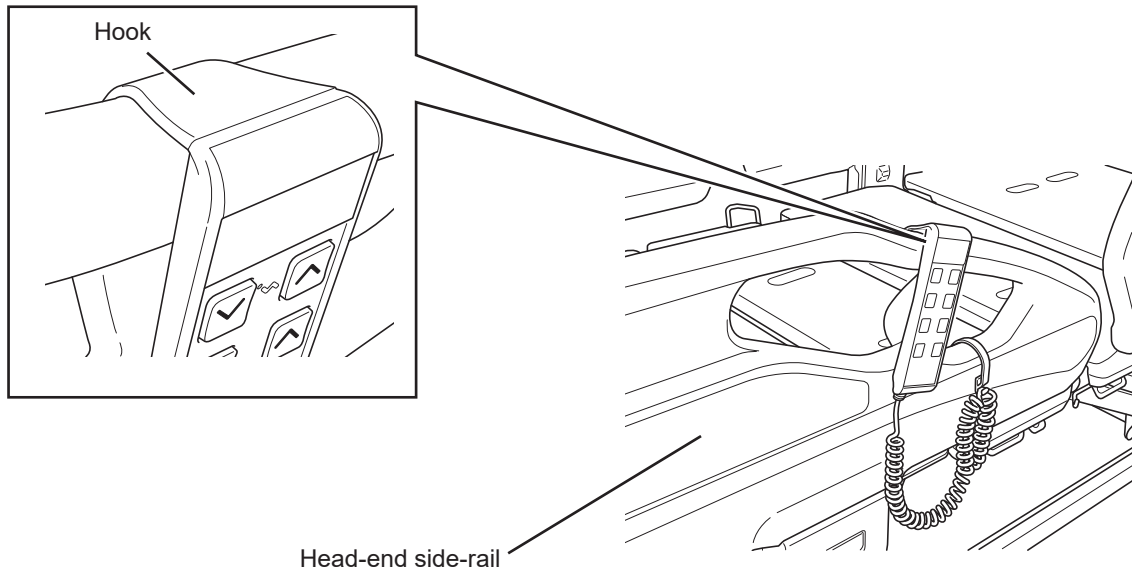

1 BEFORE USING THE BED

Connecting the bed communication cable (commercially available product)



WARNING

- Use a suitable bed communication cable. A nurse call may not be made or an equipment failure may occur when an unsuitable cable is used.
- Before moving the bed, disconnect the bed communication cable from the bed or the nurse call system on the wall. Furthermore, do not apply excessive force to the bed communication cable or run over it with the bed. A nurse call may not be made due to an equipment or cable failure.



- Be sure to check the operation after connecting the bed communication cable.
- For details on the suitable bed communication cable and suitable nurse call system, contact Paramount Bed (see p. 122) or your distributor.

Connecting to the nurse call system enables a nurse call to be made at the following times.

- When BED EXIT ALARM detects a change in the status of the patient (For details on BED EXIT ALARM, see p. 52 to 55.)
- When the nurse call auxiliary button of the bed is pressed (For details on the nurse call auxiliary button, see p. 61, 65, and 66.)

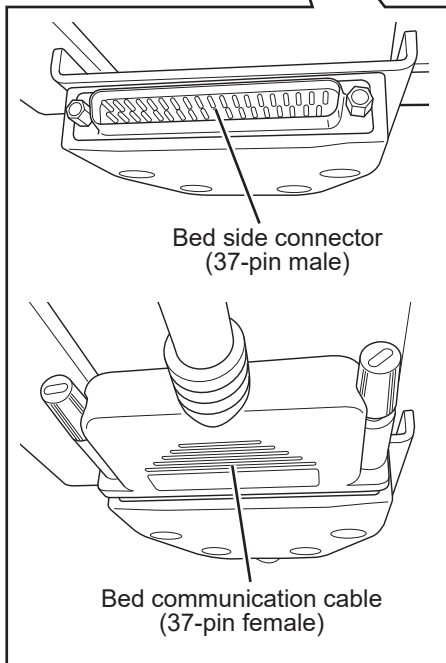
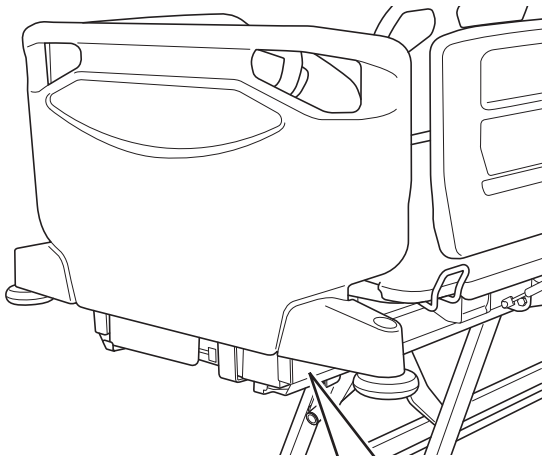

<Connecting the cable>

1. Connect the bed communication cable (37-pin female) to the bed side connector of the bed.
2. Connect the other end of the bed communication cable (37-pin male) to the nurse call wall plate.

<Checking the operation>

1. Insert the power plug into the outlet.
2. Press the nurse call auxiliary button located at the Head-end side-rail.
3. Check that the LED lamp above the nurse call auxiliary button turns on and a nurse call is made.



LED lamp

Nurse call auxiliary button

2 FUNCTIONS AND OPERATIONS

1. Bed functions

 WARNING	<ul style="list-style-type: none"> ● When performing a positioning operation, make sure that the patient's head, arms, legs, or other body parts have not entered the gap between the bed and side-rail, or between the head section and frame. They may get caught, resulting in injury. ● When adjusting the height or inclination angle with the side-rail lowered, do not put your legs under the side-rail. They may get caught, resulting in injury. ● Do not allow the patient to get in or out of the bed while the bed is inclined or the knee section is raised. The patient may fall down or fall over, resulting in injury. ● Performing the Trendelenburg/reverse Trendelenburg operation of the bed or head up using Cardiac Chair motion shall be allowed only under observation of a physician or a nurse. You may accidentally injure yourself. ● Be careful of lines during bed operation. Lines may be pulled, resulting in injury or damage to the lines or equipment.
--	---

Head up / Knee up / Head and knee coordination / Height adjustment

The angle of the head and knee sections and the bed height and Trendelenburg/reverse Trendelenburg angle (see p. 50) can be electrically adjusted with no increments. (For the operation procedure, see p. 59 to 66)

<Head up>

Head end

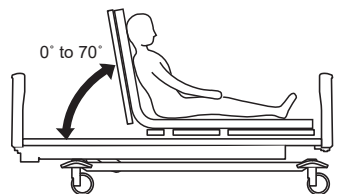

Foot end



- You can adjust the angle of the head section. You can adjust the head section from an angle of 0° to 70°.



Note! The angle of the head section relative to the floor is displayed on the BED Navi (accessory) / handheld controller (accessory) / head angle indicator.

<Knee up>

Head end

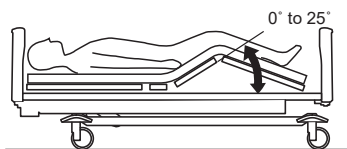

Foot end



- You can adjust the angle of the knee section. You can adjust the knee section from an angle of 0° to 25°.



Note! The angle of the knee section relative to the floor is displayed on the BED Navi (accessory) / handheld controller (accessory).

<Head and knee coordination>

Head end

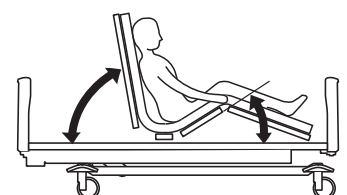

Foot end



- You can adjust the angles of the head section and knee section. You can adjust the head section angle from 0° to 70°, and the knee section angle from 0° to 25°.

2 FUNCTIONS AND OPERATIONS

<Height adjustment>

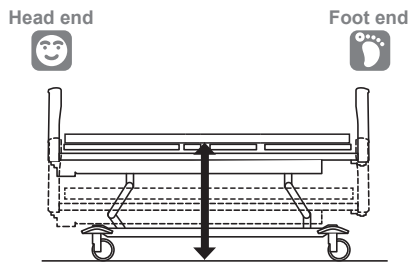

For the dimensions,
see the table below.

- You can adjust the bed height.
You can adjust the height from the floor to mattress deck top in the range shown below.

125 mm single-wheel with resin cover	40.8 to 85.8 cm
125 mm single-wheel with iron cover (total lock)	41.3 to 86.3 cm
125 mm double-wheel with resin cover	40 to 85 cm
125 mm single-wheel with iron cover (individual lock)	41.3 to 86.3 cm
150 mm single-wheel with resin cover	43.8 to 88.8 cm

■ Pause function

When lowering the bed, an alarm sounds and the movement is stopped when the height from floor to mattress deck top (floor height) reaches 43 cm to ensure safety. Press the down button again to lower the bed to its minimum height while the alarm sounds continuously.

* Lowering a side-rail with a floor height of 43 cm creates a gap of 14 cm between the floor and side-rail.



If you operate the bed with a floor height of lower than 43 cm, the bed is lowered all the way down to the minimum height without stopping while the alarm sounds continuously.

Trendelenburg/reverse Trendelenburg

<Trendelenburg>

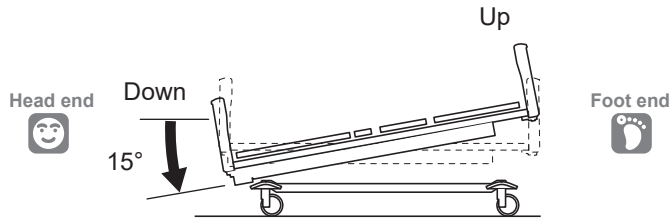

- You can lower the head end of the bed to a maximum angle of 15°. (See p. 62)
- * When inclining the bed in a range from the lowest position (see the table below) to less than 43 cm, the bed rises to a height of 43 cm and then performs the Trendelenburg/reverse Trendelenburg operation.



When performing the Trendelenburg operation with the head end of the bed raised, the operation is stopped when the bed becomes horizontal. To further perform the Trendelenburg operation, press the operation button again to lower the head end.

<Reverse Trendelenburg>

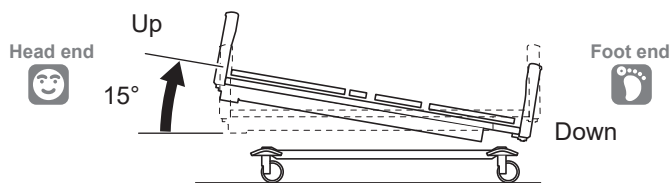

- You can raise the head end of the bed to a maximum angle of 15°. (See p. 62)
- * When inclining the bed in a range from the lowest position (see the table below) to less than 43 cm, the bed rises to a height of 43 cm and then performs the Trendelenburg/reverse Trendelenburg operation.



When performing the reverse Trendelenburg operation with the head end of the bed lowered, the operation is stopped when the bed becomes horizontal. To further perform the reverse Trendelenburg operation, press the operation button again to raise the head end.

2 FUNCTIONS AND OPERATIONS

Cardiac Chair motion

Cardiac Chair motion ("Cardiac Chair") is a function to reduce the feeling of pressure or slippage to help the patient maintain a better posture by alternately or simultaneously performing the head up, knee up, and inclining operations. The function has the following features.

- To reduce the feeling of pressure when performing the head up operation.
- To significantly reduce slippage of the body when performing the head up and head down operation.
- To firmly maintain a posture when performing the head up operation.

<Cardiac Chair up>

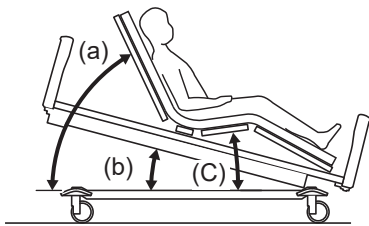

The Cardiac Chair up operation moves the bed to the position in the table below.

Operation part	Angle of head section (a)	Inclination angle of bed (b)	Angle of knee section (c)
Position	65°	15°	10°



Note! The part that moves when pressing the button varies depending on the posture when the operation is started.

<Cardiac Chair down>

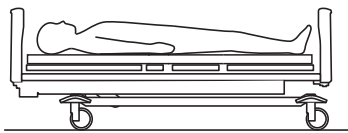

The Cardiac Chair down operation moves the bed to the position in the table below.

Operation part	Angle of head section (a)	Inclination angle of bed (b)	Angle of knee section (c)
Position	0°	0°	0°



Note! The part that moves when pressing the button varies depending on the posture when the operation is started.

BED EXIT ALARM

- This function measures load changes on the bed with sensors built into the bed and notifies the status of a patient who may fall off or fall down.
- The following notification functions can be used with BED EXIT ALARM. BED EXIT ALARM causes an alert when it detects the patient's movement. Also a notification can be made to the nurse call system by connecting it to the nurse call wall plate with a nurse call relay unit (accessory) ("relay unit") or a bed communication cable.
 - MONITORING
 - LEFT BED
 - EDGE OF BED
 - SIT-UPEach function is set using the relay unit. For connecting to the nurse call system and details on handling, see "Connecting the bed communication cable" (see p. 47) or the instruction manual for the relay unit.
- If a power failure occurs, all bed functions including BED EXIT ALARM stop, so the patient status cannot be notified by BED EXIT ALARM. If necessary, connect the power plug of the bed to an emergency power supply.



- This product is just an assisting device to detect out-of-bed and does not guarantee safety. A false notification or absence of notification may occur depending on the motion or lying position of the patient. We assume no responsibility whatsoever for any damages resulting from an accident, etc.
- The bed communication cable and relay unit may not be suitable depending on the type of nurse call system. For details, contact Paramount Bed (see p. 122) or your distributor.
- To use BED EXIT ALARM, you need to set the notification function settings (for the setting procedure, see the instruction manual for the relay unit).
- Before using BED EXIT ALARM for the first time after the bed is installed, make sure that notification is made correctly before use.
- If notification is not made or any other errors occur, stop using BED EXIT ALARM and check the bed and bed communication cable, or relay unit by referring to "1. Troubleshooting" on p. 98 to 101.

2 FUNCTIONS AND OPERATIONS



WARNING

■ Notification is not made during bed operation (e.g., head up, height adjustment) even if the patient gets out of the bed or sits up on the bed. Furthermore, getting into or out of the bed during bed operation may cause the patient to fall off or fall over, resulting in injury. If you consider that the patient may get in or out of the bed during bed operation, set Overall lock-out or Patient lock-out (see p. 64).

■ Before using BED EXIT ALARM, set the notification function properly (for the setting procedure, see the instruction manual for the relay unit). If the settings are not correct, detection may not work and notification may not be made, and the patient may fall off or fall over, resulting in injury. Even when the settings are correct, detection may not work and notification may not be made in the following cases.

- If it takes 4 minutes or more for the patient to get out of the bed or sit up on the bed
- If the patient gets out of the bed or sits up on the bed after a heavy object (which weighs more than half the patient's weight) is placed on the bed
- If the patient who is lying at the foot end of the bed sits up (SIT-UP function)

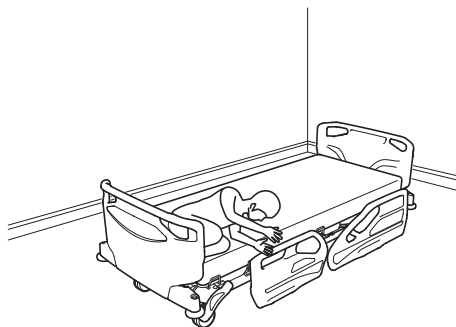

- If the patient sits up while placing his or her hand or elbow on the top of the head end of the bed (SIT-UP function)

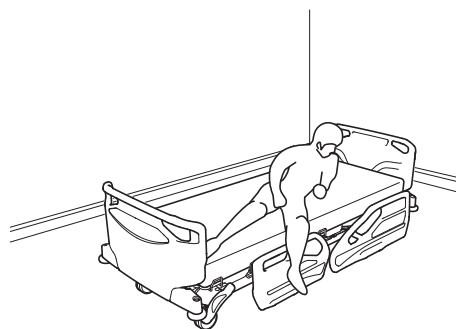

■ When using BED EXIT ALARM, use it at a temperature between 15°C and 30°C and humidity between 30% RH and 75% RH. The detection accuracy may decrease, notification may not be made, and the patient may fall off or fall over, resulting in injury.

■ Do not place objects such as furniture and fixtures between the bed and floor. Detection may not work and the patient may fall off or fall over, resulting in injury.



WARNING

- If the patient does not stay in bed without moving for 5 seconds or more after returning to the bed, detection may not work, notification may not be made, and the patient may fall off or fall over, resulting in injury.
- If the patient does not stay in bed without moving for 5 seconds or more after bed operation, detection may not work, notification may not be made, and the patient may fall off or fall over, resulting in injury.



<False notification>

- If the notification functions are not set correctly, an accidental notification may be made.
- Notification may be made in the following cases. In such a case, turn off or pause notification.
 - If a person other than the patient gets into or out of the bed
 - If the patient rolls over to the foot end of the bed
 - If an object of 3 kg or heavier is removed from the bed
 - If the board is detached from the bed
 - If the weight is applied to the footboard
- The larger the angle of the head section is, the higher is the possibility that the SIT-UP notification function will detect a slight movement such as rolling over and will make notification, even when the patient does not sit up.

2 FUNCTIONS AND OPERATIONS

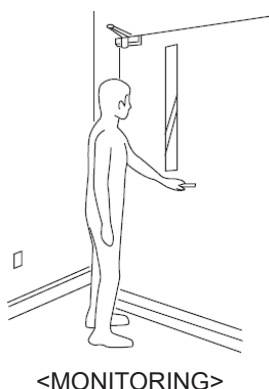
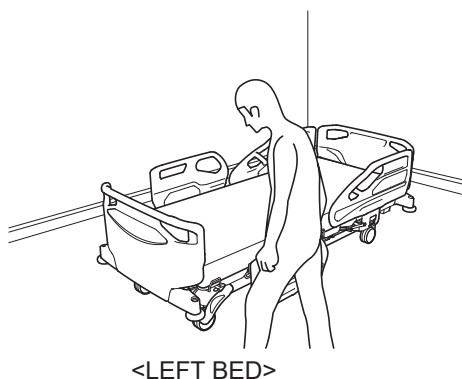
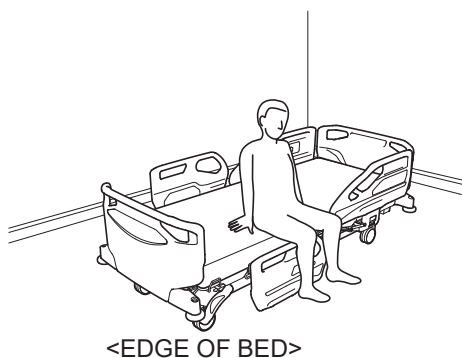
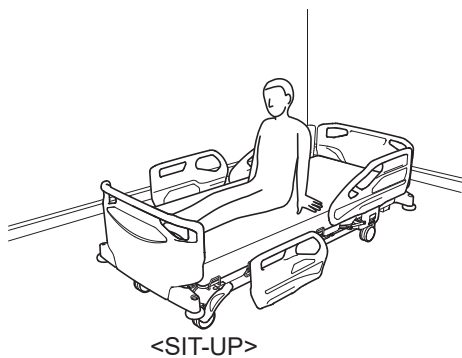

<SIT-UP>

When the patient sits up in bed, notification is made through the nurse call system. The setting period can be selected from 0 second, 1 second, and 3 seconds.

- * If the patient sits down on the edge of the bed or gets out of the bed within 4 minutes after sitting up, notification is made only when the patient sits up to avoid repeated notifications. If it takes 4 minutes or more for the patient to sit down on the edge of the bed or gets out of the bed after sitting up, notification is made. If the patient sits up and then lays down in the bed again, notification is made if the patient sits up again even within 4 minutes.
- * If the patient turns over in bed and his or her body leaves the bed or his or her feet touch the floor, it is determined that the patient sat up on the edge of the bed or got out of the bed, and notification is made, even though the patient did not sit up.

<EDGE OF BED>

When the patient sits down on the edge of the bed and body weight is applied to the floor, notification is made through the nurse call system.

- * To avoid repeated notifications, notification is made at the following times (or when the following conditions are met).
 - If the patient gets out of the bed within 4 minutes after sitting down on the edge of the bed, notification is made only when the user first sits down on the edge of the bed.
 - If the patient gets out of the bed after 4 minutes or more have passed after sitting down on the edge of the bed, notification is made.
 - If the patient sits down on the edge of the bed and then lays down in the bed again, notification is made if the user sits down on the edge of the bed again even within 4 minutes.
- * If the patient gets out of the bed without sitting down on the edge of the bed, notification is made.

<LEFT BED>

If the patient gets completely out of bed, notification is made through the nurse call system.

<MONITORING>

If the patient is out of bed for longer than the set period, notification is made through the nurse call system. The setting period can be selected from 1 minute, 3 minutes, 5 minutes, 10 minutes, and 30 minutes.

- * If the patient gets completely out of bed, notification is made through the nurse call system.

X-ray cassette imaging (type with X-ray cassette tray only)

 WARNING	<ul style="list-style-type: none"> ● Disconnect the power plug from the outlet and turn the battery off when using X-ray equipment. The bed may malfunction resulting in injury or damage. ● Do not perform X-ray imaging using a cassette tray while an air mattress is installed. The X-ray imaging results may be affected by reflections of parts of an air mattress.
--	---

 CAUTION	<p>Use a cassette of the specified size. If other than the specified one is used, the cassette may fall, resulting in injury or cassette damage or deformation.</p>
--	---

You can perform X-ray imaging using a cassette within the range of the diagonal lines in the figure below.

Supported cassette sizes	Size..... Half: 38.8 x 46.4 cm or less Square: 38.8 x 38.8 cm or less Thickness 1.5 cm or less Weight 3.5 kg or less
--------------------------	---

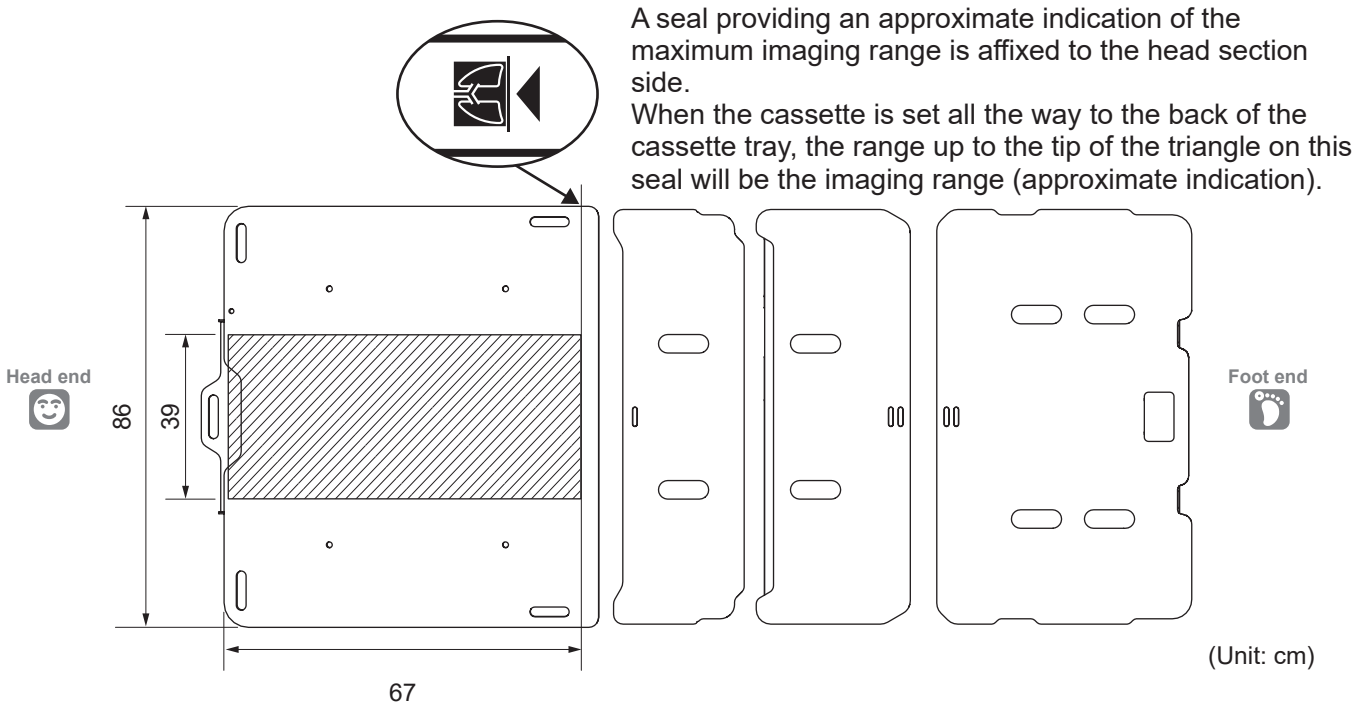

- When performing imaging by raising the head section, set the cassette all the way to the back of cassette tray. In this case, the imaging range will be narrower than the range indicated in the figure above.
- X-ray imaging in an inclined state (Trendelenburg position) is not possible.

2 FUNCTIONS AND OPERATIONS

<Cassette setting procedure>

Set a cassette while the head section is in a horizontal state.



CAUTION

- When unlocking the locking lever, pull it toward you all the way until it stops. Otherwise, the lever may be damaged or deformed when the cassette tray is operated.
- While pulling out the cassette tray, do not change the locking lever from the unlocked state. Otherwise, the lever may be damaged or deformed when the cassette tray is operated.

Foot end

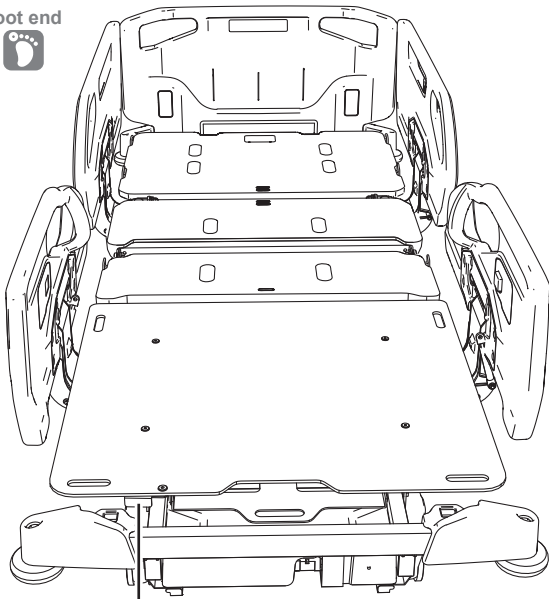

Head end



Locking lever

1. Detach the headboard. (See p. 28)

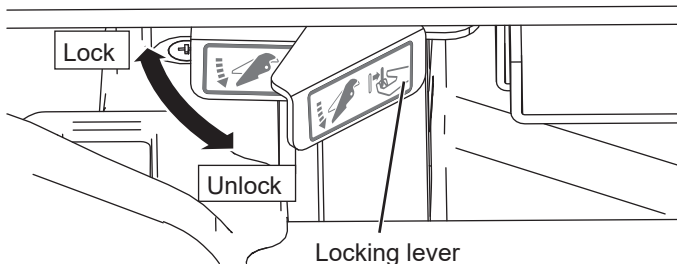

2. Pull the locking lever toward you to unlock it.

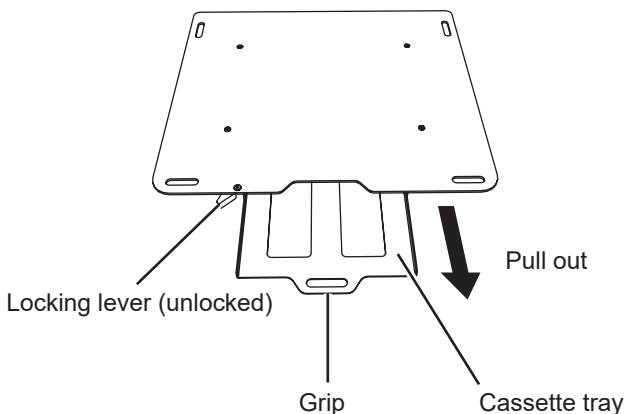

3. Hold the grip and pull the cassette tray all the way out.



CAUTION

- Operate the cassette tray slowly. Not doing so may cause the cassette to be out of position resulting in imaging problems.
- Hold the grip when operating the cassette tray. Not doing so may cause your hand or fingers to be caught and injured.
- Other than when setting a cassette, use the bed with the cassette tray pushed in all the way to the back and the locking lever locked. Otherwise, the cassette tray or cassette may come out due to bed operation, resulting in injury or cassette damage or deformation.
- Do not incline the bed while a cassette is set. The cassette may come out, resulting in injury or cassette damage or deformation.

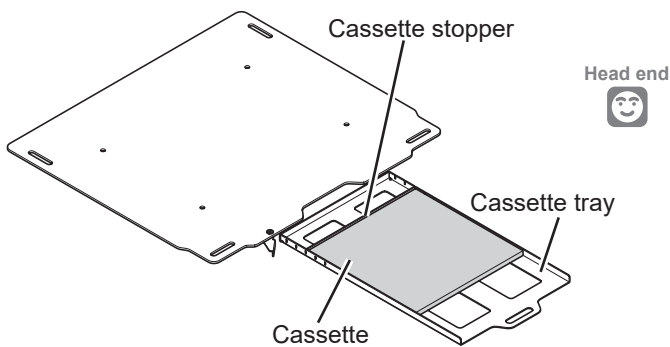

* Cassette position when used for imaging of the head

4. Set the cassette stopper to the appropriate position. The cassette stopper can be adjusted to 5 levels.

5. Set a cassette in the cassette tray.



For imaging of the chest, set the cassette all the way to the back of the cassette tray.

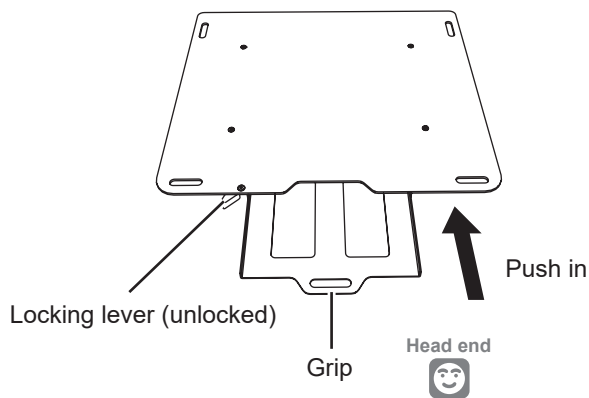

6. Hold the grip and slowly push the cassette tray all the way to the back.

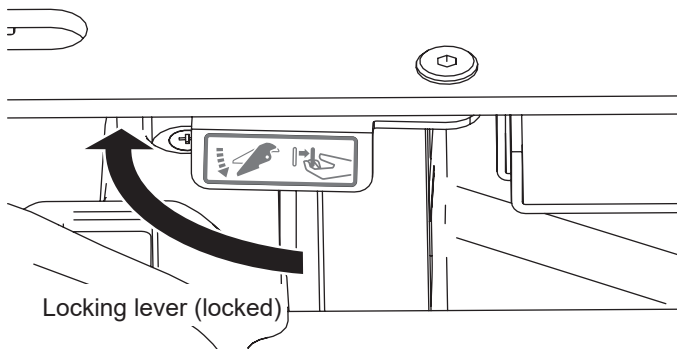

7. Push the locking lever until it locks into place.

2 FUNCTIONS AND OPERATIONS

2. Operation procedure

Using the side-rail integrated panel

The side-rail integrated panel is intended for operation by physicians, nurses, and other medical professionals. It is located on the outside of the left or right Head-end side-rail.

 WARNING	<ul style="list-style-type: none"> ● Do not apply excessive force to the side-rail integrated panel or touch it with sharp objects. The side-rail integrated panel may be damaged, resulting in electric shock or malfunction. ● Do not allow it to be operated by a person deemed incapable of understanding the operation (a child aged 12 or under or a person with dementia). If a person deemed incapable of understanding the operation operates the side-rail integrated panel by oneself, a body part may get caught in the bed by mistake, resulting in unexpected injury. When such a person runs the risk of operating the side-rail integrated panel by oneself, you can use one of the following procedures to limit operation and decrease the chance of injury. <ul style="list-style-type: none"> • Set Overall lock-out on the side-rail integrated panel to disable the operation of the side-rail integrated panel. (For the setting procedure, see p. 64.) • Disconnect the power plug and turn the battery off.
--	---

<Part names and functions>

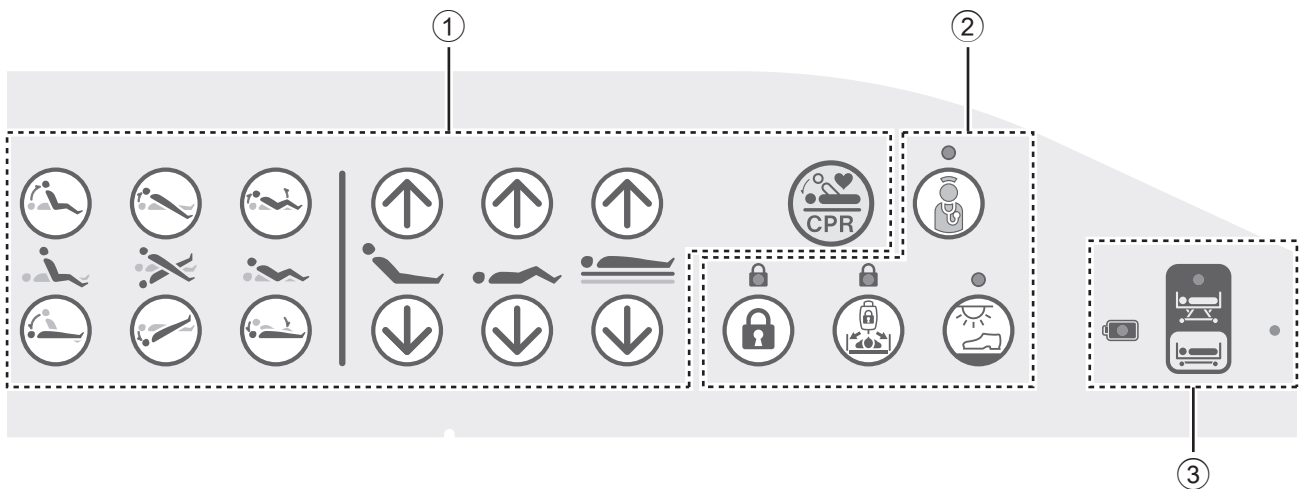

- ① Bed operation buttons ... Perform each bed positioning operation and electric CPR operation.
- ② Function buttons Make a nurse call, set Patient lock-out and Overall lock-out, and perform foot light operations.
- ③ Status indication Indicates the battery status, bed height status, and whether or not an error occurred by lamp flashing and brightness/darkness.

■ Bed operation buttons

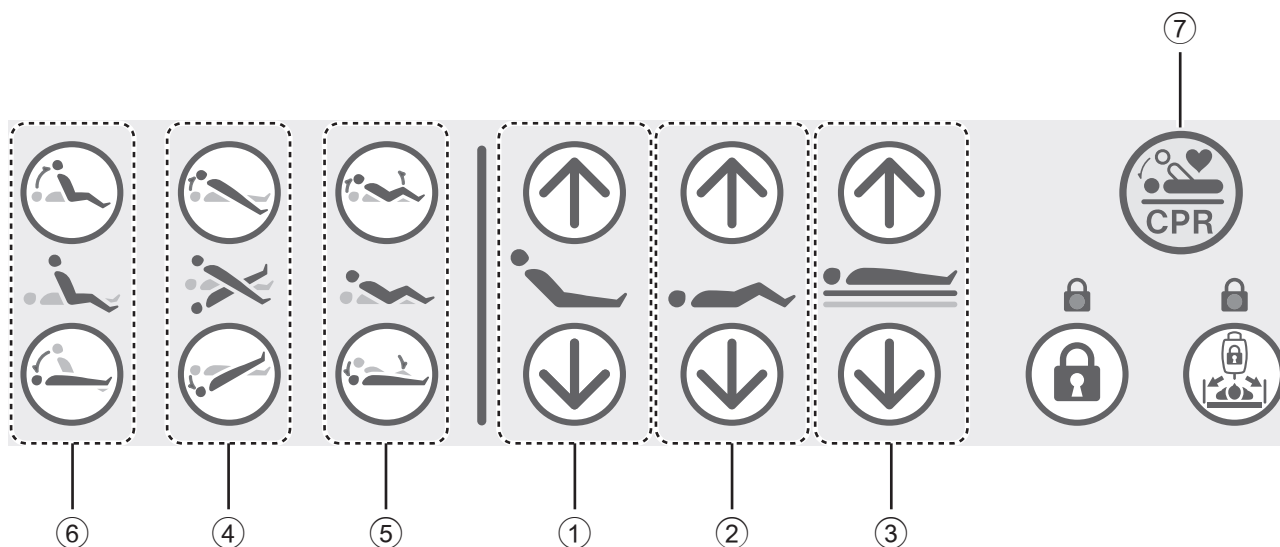

- ① Head up/down buttons.....Adjust the angle of the head section.
- ② Knee up/down buttons.....Adjust the angle of the knee section.
- ③ Height up/down buttons.....Adjust the bed height.
- ④ Trendelenburg/reverse Trendelenburg buttonsAdjust the inclination angle of the bed.
- ⑤ Head and knee coordination buttons.....Adjust the angle of the head/knee sections.
- ⑥ Cardiac Chair buttons.....Adjust the angle of the head/knee sections and the inclination angle of the bed in Cardiac Chair motion.
- ⑦ Electric CPR buttonFlattens the inclined head/knee sections and bed.

2 FUNCTIONS AND OPERATIONS

Function buttons

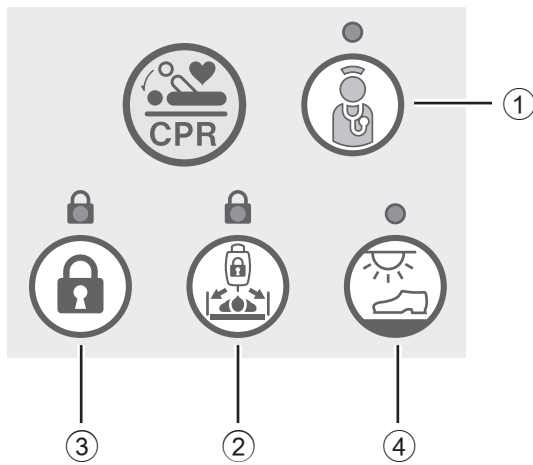

- ① Nurse call auxiliary button
..... Used to make a nurse call.
* The bed and nurse call wall plate need to be connected with the bed communication cable (commercially available product).
- ② Patient lock-out button
..... Used to block the operation of the patient control panel and handheld controller (accessory).
- ③ Overall lock-out button
..... Used to block all bed operations except for electric CPR.
- ④ Foot light button
..... Used to turn the foot light on.

Status indication

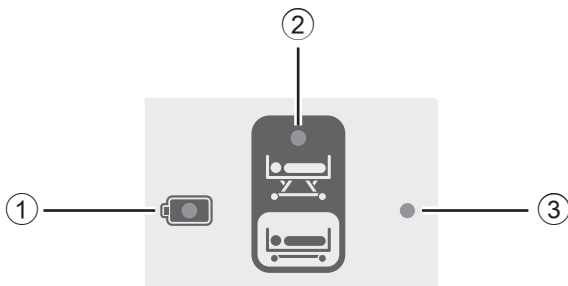

- ① Battery status indicator lamp
..... Flashing, etc. indicates the battery status.
- ② Low height indicator lamp
..... Minimum height: lamp turns off, otherwise: lamp turns on
- ③ Error indicator lamp
..... Fast/slow flashing orange light indicates that an error has occurred.

<Operation procedure>

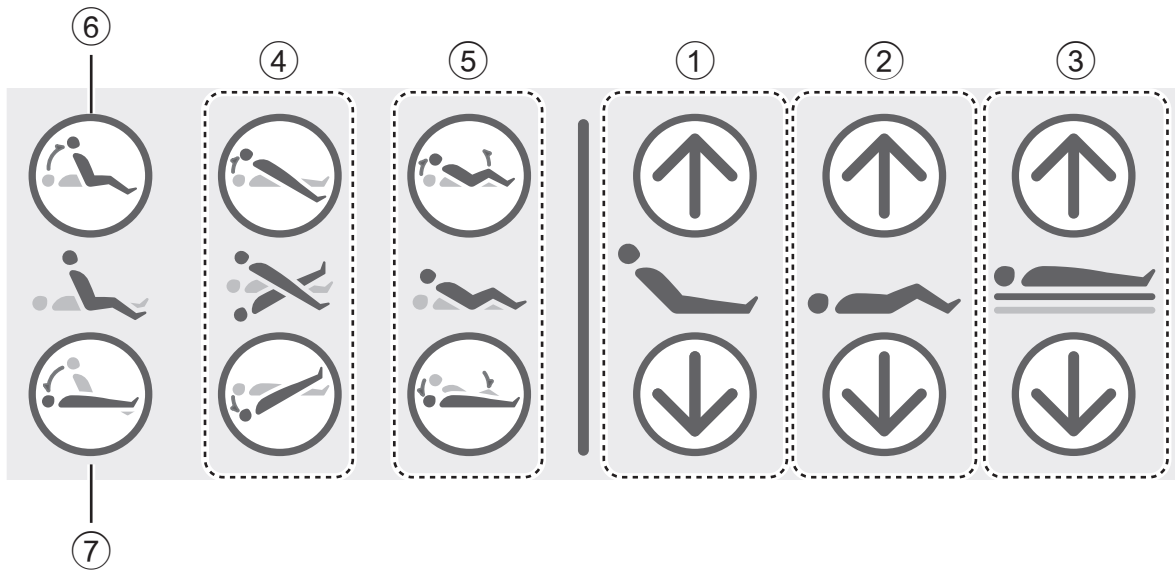

Head up/down

Press the button ① to raise the head section and press the button to lower it.
* Releasing the button stops the operation at its position.

Knee up/down

Press the button ② to raise the knee section and press the button to lower it.
* Releasing the button stops the operation at its position.

Height up/down

Press the button ③ to raise the bed and press the button to lower it.
* Releasing the button stops the operation at its position.

Trendelenburg/reverse Trendelenburg

Press the button ④ to lower the head end of the bed (Trendelenburg).

Press the button ④ to raise the head end of the bed (reverse Trendelenburg).

* Releasing the button stops the operation at its position.



If the bed is inclined, the operation is paused when the bed becomes horizontal. To incline the bed further, press the button again.

Head and knee coordination

Press the button ⑤ to raise the head and knee sections.

Press the button ⑤ to lower the head and knee sections.

* Releasing the button stops the operation at its position.

Cardiac Chair up

Press the button ⑥ to incline the bed while simultaneously adjusting the angle of the head/knee sections.

* Releasing the button stops the operation at its position.

Cardiac Chair down

Press the button ⑦ to adjust the inclined head/knee sections and bed to the horizontal position.

* Releasing the button stops the operation at its position.

2 FUNCTIONS AND OPERATIONS



WARNING

- Use the nurse call auxiliary button of this product as an auxiliary button, and place the call button unit within the range where it can be operated by the user. In the following cases, notification to the nurse call system may not be possible even though the nurse call auxiliary button of this product is pressed.
 - When the power plug of the bed is not inserted into an outlet
 - When power is not supplied to the bed due to a power failure or other problem
 - When the bed communication cable is not connected appropriately
 - When the bed communication cable is damaged



- When the nurse call auxiliary button of this product will be used, be sure to check the operation after connecting the bed communication cable.
 - Check procedure
 - (1) Press the nurse call auxiliary button.
 - (2) Check that the LED lamp above the nurse call auxiliary button turns on and a nurse call is made.
- If the LED lamp above the nurse call auxiliary button does not turn on and the nurse call is not made when the button is pressed, see “1. Troubleshooting” (p. 98 to 101) and then check the bed and cable. If correct operation is not possible even after taking corrective action, stop using the nurse call auxiliary button of this product and use the call button unit.
- For details on the suitable nurse call system and suitable bed communication cable, contact Paramount Bed (see p. 122) or your distributor.

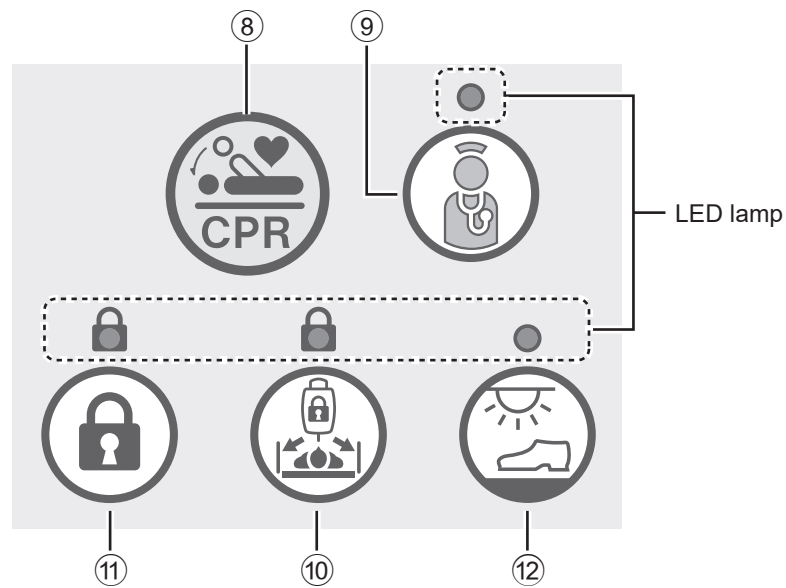

Electric CPR

Hold down the  button ⑧ for at least 2 seconds or press it twice quickly to operate the bed so the head/knee sections and inclination angles become 0° (horizontal).

- * The bed is lowered to the pause position.
- * Releasing the button stops the operation at its position.

Nurse call auxiliary button

Press the  button ⑨ to make a nurse call.

- * If a call is made correctly when the button is pressed, the LED lamp above the button turns on.
 - * When staff answer the call, the LED lamp turns off.
- If the LED lamp does not turn on, use the call button unit.

Patient lock-out

Press the  button ⑩ to disable the operation of the patient control panel and handheld controller (accessory).

- * The LED lamp is on when disabled.

Overall lock-out

Press the  button a to disable all bed operations except for electric CPR.

- * The LED lamp is on when disabled.

Foot light (suitable product)

Press the  button b to operate the foot light on the back of the hip section as follows.

- Press the button once to set dark mode.
- Press the button twice to set bright mode.
- Press the button three times to turn off the light.

- * The LED lamp is on when the bright or dark mode is set.

2 FUNCTIONS AND OPERATIONS

Using the patient control panel

<Part names and functions>

The patient control panel is intended for patients to perform the following operations. It is located on the inside of the left or right Head-end side-rail.

- Adjusting the angle of the head/knee sections
- Charging USB devices (on the right side only when the patient is lying down)



WARNING

● Do not apply excessive force to the patient control panel or touch it with sharp objects. The patient control panel may be damaged, resulting in electric shock or malfunction.

● Do not allow it to be operated by a person deemed incapable of understanding the operation (a child aged 12 or under or a person with dementia). If a person deemed incapable of understanding the operation operates the patient control panel by oneself, a body part may get caught in the bed by mistake, resulting in unexpected injury.

When such a person runs the risk of operating the patient control panel by oneself, you can use one of the following procedures to limit operation and decrease the chance of accident caused by incorrect operation.

- Set Overall lock-out on the side-rail integrated panel or BED Navi (accessory) to disable the operation of the patient control panel. (For the setting procedure, see p. 64 or the instruction manual for the BED Navi (accessory).)
- Set Patient lock-out on the side-rail integrated panel or BED Navi (accessory) to disable the operation of the patient control panel. (For the setting procedure, see p. 64 or the instruction manual for the BED Navi (accessory).)
- Disconnect the power plug and turn the battery off.

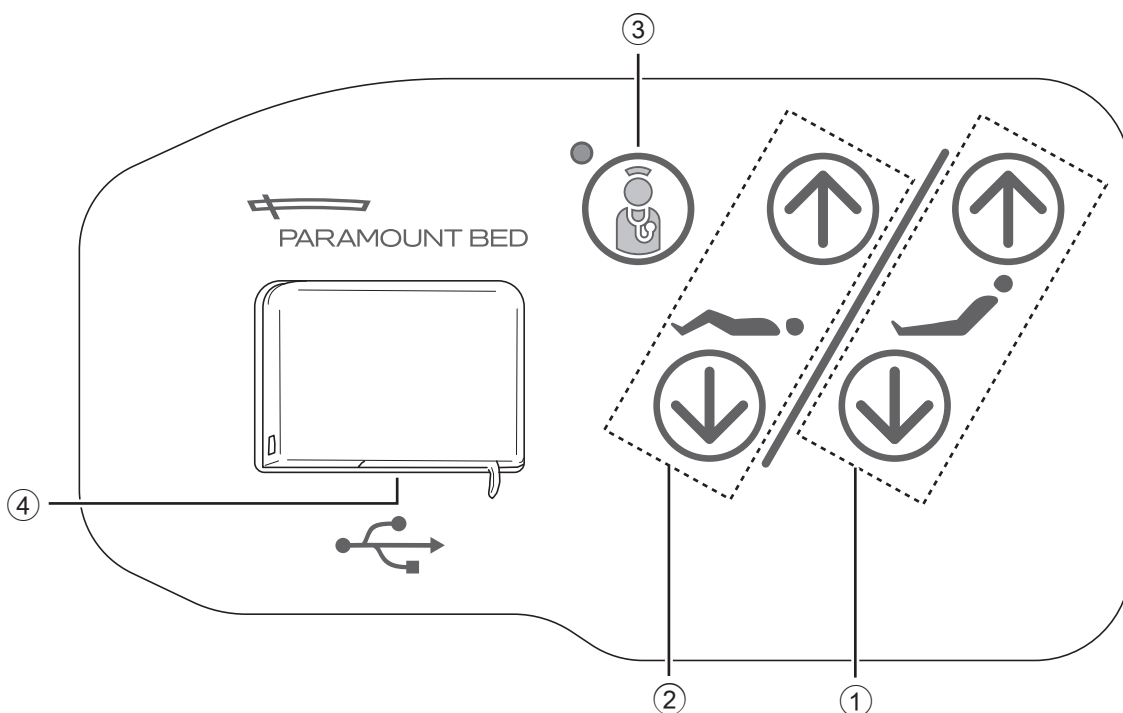

- ① Head up/down buttons..... Adjust the angle of the head section.
- ② Knee up/down buttons..... Adjust the angle of the knee section.
- ③ Nurse call auxiliary button Makes a nurse call.
- ④ USB port..... Charges a smartphone or tablet.

<Operation procedure>



WARNING

- Use the nurse call auxiliary button of this product as an auxiliary button, and place the call button unit within the range where it can be operated by the user. In the following cases, notification to the nurse call system may not be possible even though the nurse call auxiliary button of this product is pressed.
 - When the power plug of the bed is not inserted into an outlet
 - When power is not supplied to the bed due to a power failure or other problem
 - When the bed communication cable is not connected appropriately
 - When the bed communication cable is damaged



- When the nurse call auxiliary button of this product will be used, be sure to check the operation after connecting the bed communication cable.
 - Check procedure
 - (1) Press the nurse call auxiliary button.
 - (2) Check that the LED lamp above the nurse call auxiliary button turns on and a nurse call is made.
- If the LED lamp above the nurse call auxiliary button does not turn on and the nurse call is not made when the button is pressed, see “1. Troubleshooting” (p. 98 to 101) and then check the bed and cable. If correct operation is not possible even after taking corrective action, stop using the nurse call auxiliary button of this product and use the call button unit.
- For details on the suitable nurse call system and suitable bed communication cable, contact Paramount Bed (see p. 122) or your distributor.

Head up/down

Press the  button ① on p. 65 to raise the head section and press the  button to lower it.

* Releasing the button stops the operation at its position.

Knee up/down

Press the  button ② on p. 65 to raise the knee section and press the  button to lower it.

* Releasing the button stops the operation at its position.

Nurse call auxiliary button

Press the  button ③ on p. 65 to make a nurse call.

* If a call is made correctly when the button is pressed, the LED lamp above the button turns on.

* When staff answer the call, the LED lamp turns off.

If the LED lamp does not turn on, use the call button unit.

2 FUNCTIONS AND OPERATIONS

<Using the USB port>

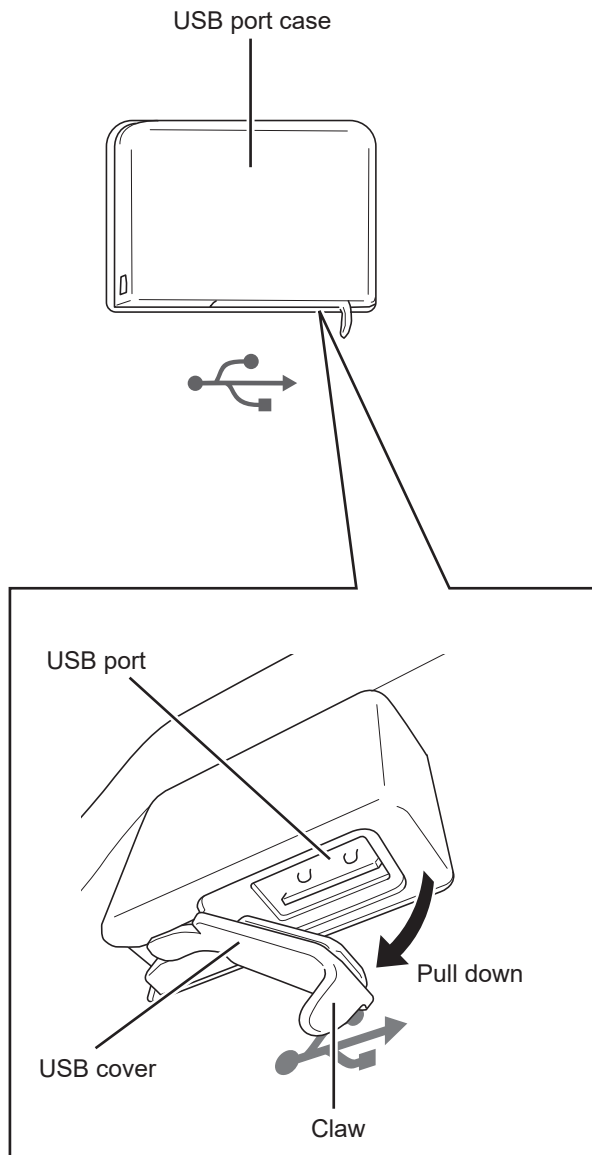

1. Pull down the claw of the USB cover on the back of the USB port case to open the USB cover. You can connect a USB device to the port.
2. After disconnecting the USB device, perform the procedure in 1 in reverse to insert the USB cover into the back of the USB port case.



CAUTION

- When detaching the USB device from the USB port, it is sometimes difficult to disconnect the cable plug for the USB device (“USB plug”). Pull out the USB plug vertically downward while firmly holding both ends of the USB plug. Forcibly pulling the cable may cause disconnection.
- The USB plug has a front and back. Before connecting a device to the USB port, check the front and back and do not forcibly connect it. The USB port and USB plug may be damaged.



The USB port is dedicated for charging. It cannot be used for data communication.

3. DS display panel

Part names

The DS display panels are located one each on the outside of the left and right Foot-end side-rails. The DS display panel can operate the scale.

Head end

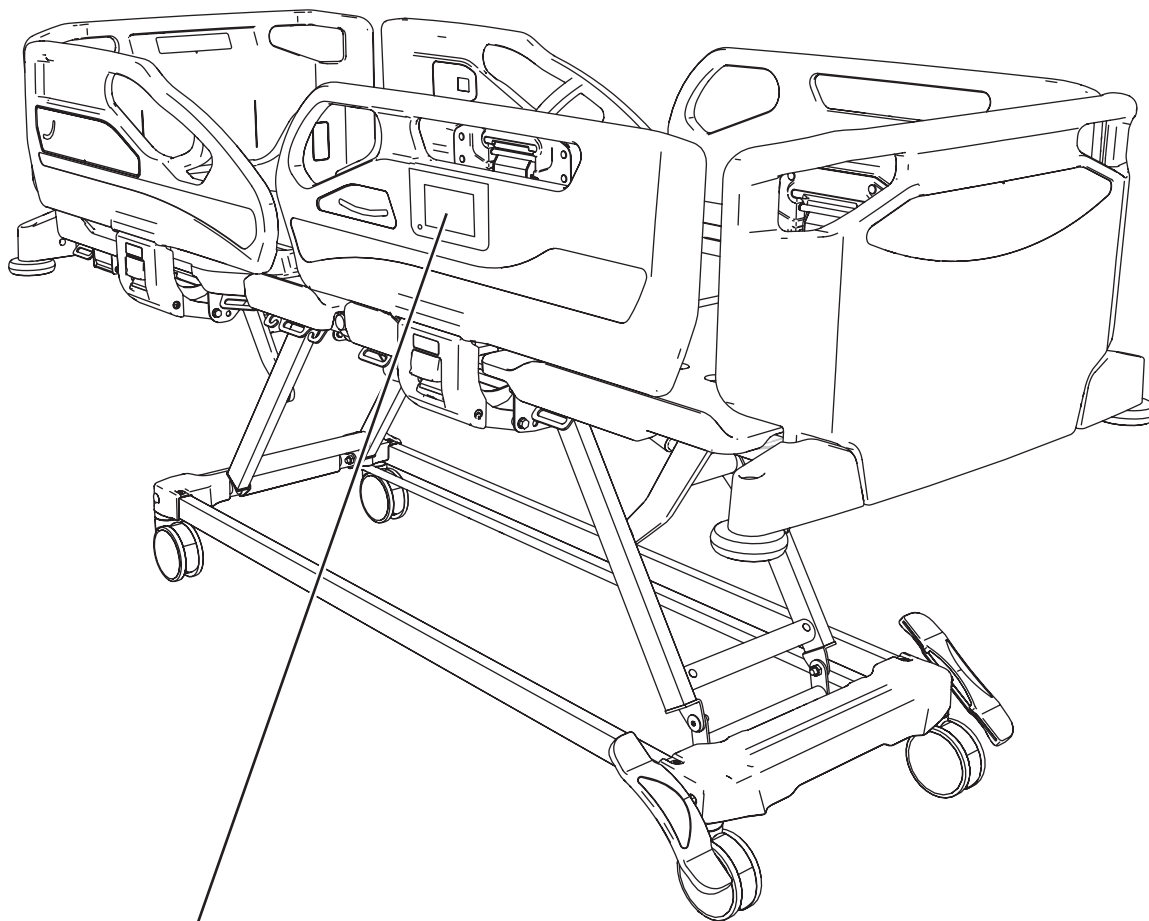

Foot end



DS display panel

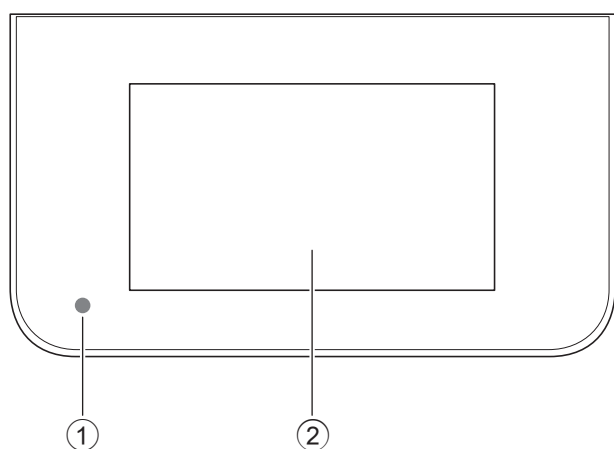

- ① Power lamp
 - On (green) : Normal power on status.
 - Flashing (orange) : Indicates a problem such as disconnection.
See "1. Troubleshooting" on p. 98 to 101.
 - Flashing (green) : Bed height lowering operation is performed below the pause height of the bed.
* The lamp also flashes green depending on the remaining power of the battery (for details, see p. 43).

- ② Touch panel
 - Operates the scale.

2 FUNCTIONS AND OPERATIONS

SCALE

<Part names and functions>

Intended use

This bed is designed to be used for patient care in medical institutions and elderly care facilities.

 WARNING	<p>The SCALE is intended to read the patient's weight variation. Under no circumstances should its reading be used for medical purposes such as diagnosis or treatment.</p> <p>Also, the reading can not be used for trading or certification.</p>
--	---

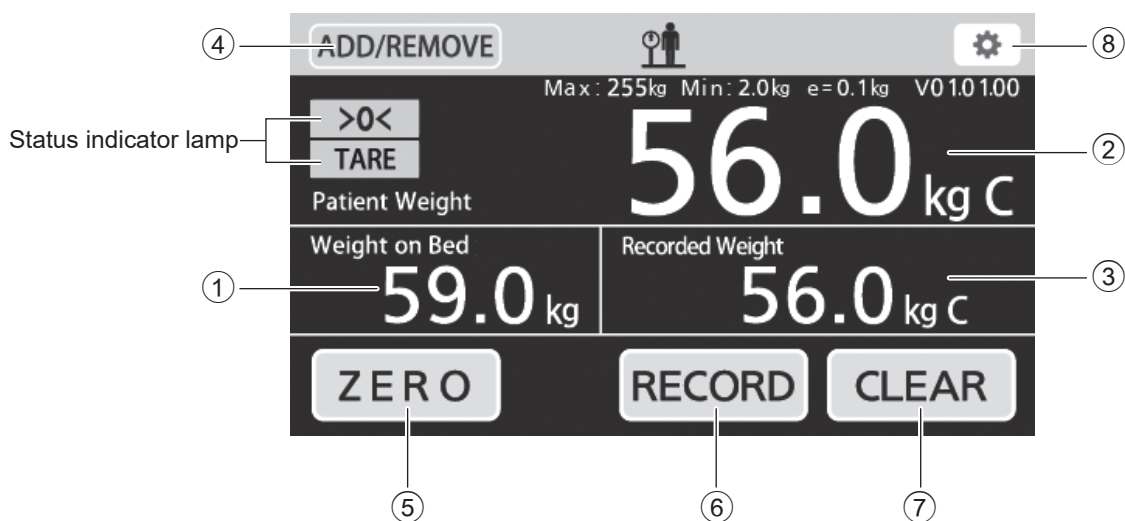

Display screen

- ① Weight on BedDisplays the weight on the bed (a weight after zero point correction^{*1)} or tare subtraction^{*2)}. (The display position varies depending on whether or not the ADD/REMOVE function is used)
- ② Patient WeightDisplays the weight after subtracting the weight of items added or removed from the bed using the ADD/REMOVE function. (See p. 71)
- ③ Recorded Weight.....Displays the last recorded weight.

*1) Zero point correction: Corrects the zero point deviation.

*2) Tare subtraction: Subtracts the weight of items except the measurement item.



Patient Weight and Recorded Weight that records the patient weight are displayed by adding C to the unit to indicate that they are calculated values.

Operation buttons

- ④ ADD/REMOVE button.....Adds or removes items. (See p. 71)
- ⑤ ZERO button.....Performs zero point correction.
- ⑥ RECORD button.....Records the measured weight. (0.0 kg or less cannot be recorded)
- ⑦ CLEAR button.....Clears the stored weight.
- ⑧ Configuration buttonDisplays the configuration screen (See p. 73)

Status indicator lamp

- >0<: The lamp is on when no load is applied to the bed.
- TARE: The lamp is on when the weight on the bed is being adjusted by subtracting the tare weight.



The >0< and TARE lamps flash during zero point correction and tare subtraction, respectively.

<Precautions for weight measurement>

Pay attention to the following points to ensure correct measurement of the weight of the patient.

- Calibrate the scale by, for example, asking a specified company to perform the work and check that weight can be measured accurately. Perform calibration using weights for which traceability is ensured.
- Take measurements within the following range.
 - Digital scale measurement range2.0 kg to 255.0 kg
 - Maximum user weight allowed on the bed..... 180 kg
- When using SCALE, insert the power plug into the outlet.
- The indication is not stable immediately after inserting the bed power plug into the outlet. It is recommended to insert the bed power plug into the outlet at least 30 minutes before measurement. If you want to be able to take measurements at any time, leave the power plug inserted into the outlet.
- Take measurements after adjusting the bed inclination angle to 0° (horizontal). If the bed is inclined, you cannot obtain correct measurement values. In addition, if the bed height is below 42 cm, you cannot take measurements. Raise the bed and then take measurements.
- When using the handheld controller (accessory), hook the handheld controller on the bed and ensure that the cable does not come into contact with the floor. The weight cannot be measured correctly.
- When recording a measured value, make sure that the medical professional taking the measurement is not touching the bed.
- If the bed height is changed, a cable (e.g., syringe pump cable) connected to the bed may be lifted and the weight value may change.
- Make sure that a person other than the patient on the bed does not touch or an item is hooked or placed anywhere within the area that impacts the weight measurement as shown in the figure below.
 - * Accessory rails that do not impact the weight measurement are located one each on the left and right of the bed.

Area that impacts the weight measurement

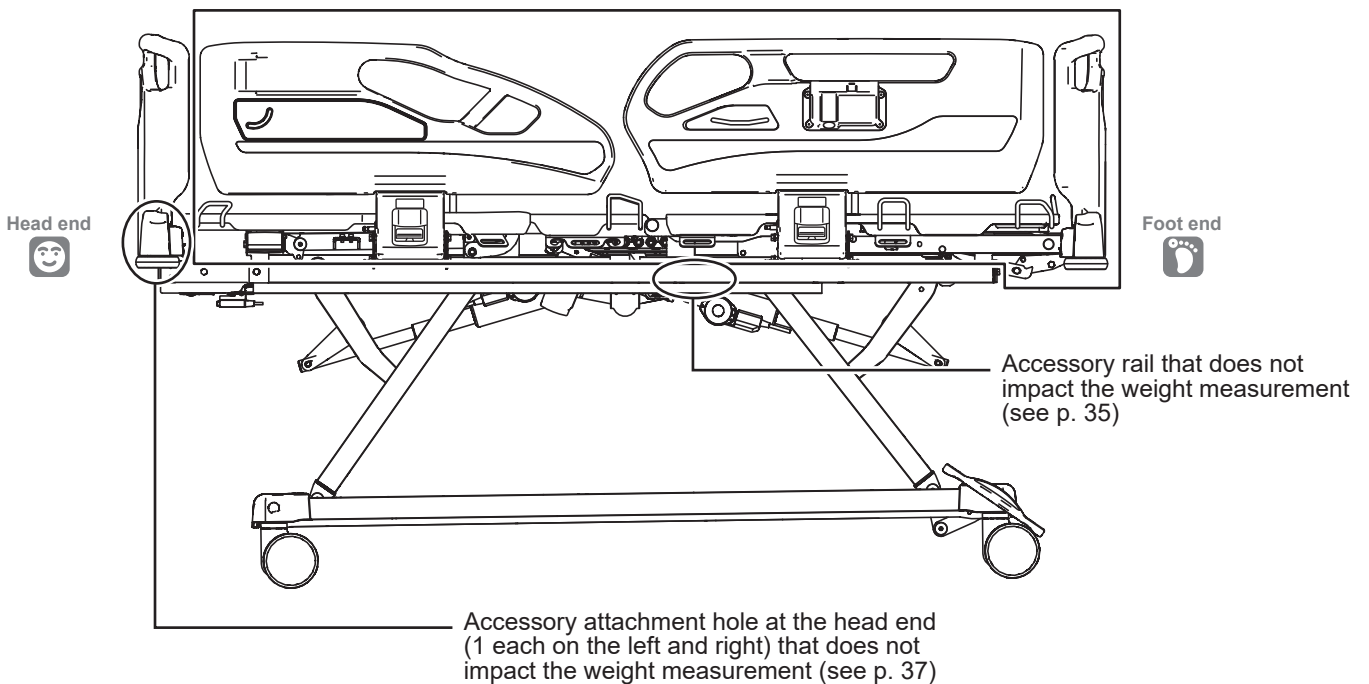

2 FUNCTIONS AND OPERATIONS

<SCALE operation>



1. Make the bed.
2. Touch the **ZERO** button in the SCALE screen to reset the weight on the bed to 0.0 kg.



It takes a couple of seconds until the weight on the bed is indicated as 0.0 kg.

3. Place the patient on the bed.

ADD/REMOVE

The weight measurement is paused. Since the weight is not measured during pause, you can add or remove items such as a blanket to or from the bed.

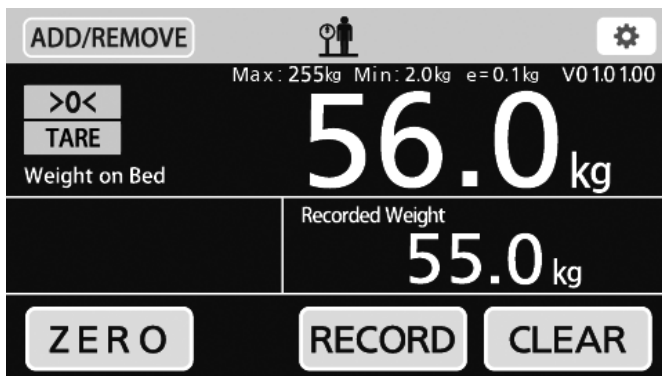

1. Touch the **ADD/REMOVE** button in the SCALE screen to start ADD/REMOVE. The weight measurement is paused.

2. Add or remove items to or from the bed. The weight on the bed changes, but the patient weight remains unchanged.

3. After adding or removing items to or from the bed, touch the **COMPLETE** button immediately to resume the measurement.



ADD/REMOVE cannot be started unless the weight on the bed is indicated as 10 kg or more.



RECORD

Record the weight. (Just one record)

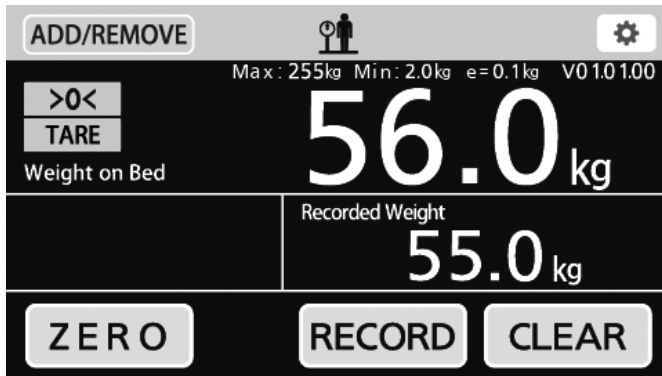

1. Check that the patient is lying on the bed.
2. Remove items that were not processed in TARE or ADD/REMOVE.

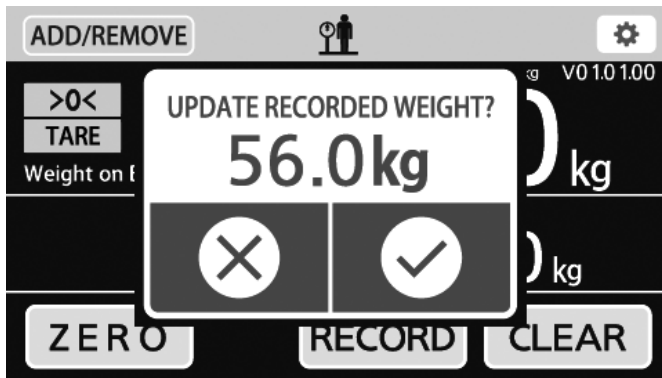

3. Touch the **RECORD** button, check the recorded weight, and update the record.

2 FUNCTIONS AND OPERATIONS

<Configuration screen>

Touch the  button on the left/right of the screen to display the configuration screen.

You can change the settings in the configuration screen by touching the button for each item. The current settings are indicated in orange.



① Language
..... You can switch the language (Japanese, English, Chinese, or Spanish).

② Operation sound
..... You can mute or unmute the operation sound during DS display panel operation.



● You cannot mute the alarm sound in the following cases.

- When the height from floor to mattress deck top has reached 43 cm and the operation is stopped when lowering the bed height.
- When you are lowering the bed height again after pausing the operation.
- During electric CPR operation.

③ Screen brightness
..... You can adjust the brightness of the touch panel and sensor indicator lamp.

④ AUTO-SLEEP
..... You can set the off time of the touch panel in case of inactivity.



The settings are not canceled even in the event of a power failure, or if the power plug is disconnected.

4. Emergency operation

In an emergency, you can easily perform the cardiopulmonary resuscitation (CPR) by operating the CPR lever attached to the head section or the electric CPR on the side-rail integrated panel.



WARNING

- When pressing the CPR button or operating the CPR lever, make sure that the patient's head, arms, legs, or other body parts have not entered the gap between the mattress deck and main frame. They may get caught, resulting in injury.
- Do not perform the emergency operation except for the CPR operation. If it is used for a purpose other than the intended purpose, the patient may fall off the bed or fall over due to bed operation, resulting in injury, or the bed may be damaged or deformed.

Lowering the head section with a CPR lever

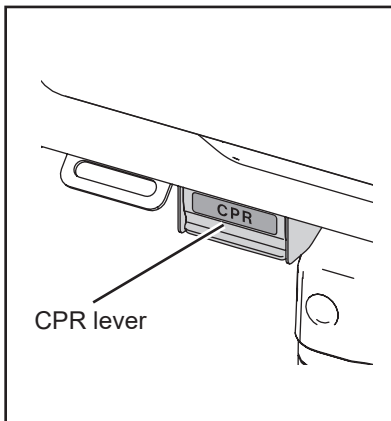

Head end

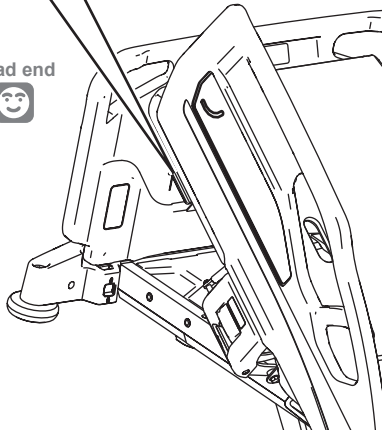

CPR levers are located on the right and left of the head section at the head end.

1. Pull the CPR lever.
2. If you release the CPR lever back halfway through, the head down operation is stopped.



- Sometimes it is difficult to lower the head section due to the weight of the patient or the angle of the head section. In such a case, strongly push the head section in the lowering direction.
- You cannot raise the head section with the CPR lever.
- You can operate the CPR lever even in the event of a power failure or bed failure.



CAUTION

- Do not operate electrical components, such as the side-rail integrated panel, during CPR lever operation. This may damage the motor.
- Do not pull the CPR levers on the left and right simultaneously. The CPR levers may be damaged.

3 SUITABLE PRODUCTS

1. Suitable products table

 WARNING	<ul style="list-style-type: none"> ● Use suitable products after confirming that the combination with the bed is correct. Using an incorrect combination of suitable products may cause accidental injury or failure. The model number of each suitable product is printed on the cardboard box and on the product ID label. * The label description may differ from the above for some products. For any queries, contact Paramount Bed (see p. 122) or your distributor. ● Use suitable products listed in the suitable products table (see below). Unintended gaps may be created and the product may be damaged or deformed, resulting in injury. ● Read the instruction manual for each suitable product. ● When connecting the bed to other equipment with cables, perform the wiring work properly. The cables may be damaged, resulting in electric shock or fire. <ul style="list-style-type: none"> • Be careful to prevent cables from getting caught in the moving parts of the bed, side-rails, etc. • Regularly check that the wiring work has been performed properly.
--	---



Suitable products may be changed due to specification changes or combinations. In addition, some suitable products may not be listed in the table due to new release or discontinuation of sales. For any queries on suitable products, contact Paramount Bed (see p. 122) or your distributor.

Suitable product* ¹⁾	Model No.	Reference page
Handheld controller	RC-1850E	77 to 81
BED Navi	NS-T130AE	82
IV pole	KC-56A, KC-56B, EC-562, IC-56A, IC-56B, IC-56C	83
Oxygen cylinder holder	PC-5038, PC-5116, PC-5117, IC-A83, IC-A84	84 and 85
Traction frame	KA-83U, KA-86U, PC-5121	86
Orthopedic frame attachment	CA-A343	86
Bedside table	KF-1900, KF-1920, KF-1930, KF-1950, KF-1960, KF-1970, KF-1924, KF-1934, KF-1954, KF-1964, KF-1974, KF-282A, PF-3100A, PF-3110A, PF-3120A, PF-3130A	95
Overbed table	KF-832LA/LB/LC, KF-833LA/LB/LC, KA-835LA/LB/LD, KF-813	96
Sittan™	KF-890, KF-840	96
Electric patient lift (floor traveling)	KQ-781, KQ-787	97
Extension mattress	PE-6410, PE-6420, PE-6411, PE-6421, IE-52EB, IE-52ED	87
Side-rail spacer/Foot spacer	PC-5112, IC-A33321Q	88
Side-rail spacer holder	PC-5118	89
Nurse call relay unit	NU-1610E, NU-1620E, NU-1640E, NU-1640EN, NU-1660E, NU-1860E	—
Lifting pole	PC-5111	90
Monitor table	PC-5119	91
Drain bag holder	PC-5120	92
Bed linen rack	PC-5060	93
Chart holder	IZ-C21CH	94

*1) In some countries or regions, some of the medical device or its accessories fall under the category of medical devices. For details, contact Paramount Bed (see p. 122) or your distributor.

2. Mattress

 WARNING	<ul style="list-style-type: none"> ● Do not use the bed without any mattress being installed. Fingers or toes may get caught in gaps or air holes on the mattress deck, resulting in injury. ● Use this bed in combination with a suitable mattress designated by Paramount Bed. If you use the bed in a combination with a mattress other than suitable mattresses designated by Paramount Bed, they may not match in dimensions and the patient may get caught in the gap between the mattress and side-rail resulting in injury, or an overload may be applied to the bed, resulting in a failure. ● Do not perform X-ray imaging using a cassette tray while an air mattress is installed. The X-ray imaging results may be affected by reflections of parts of an air mattress.
--	---

<Standard mattress>

Width	Length	Thickness
860 mm	2000 mm	90 to 150 mm

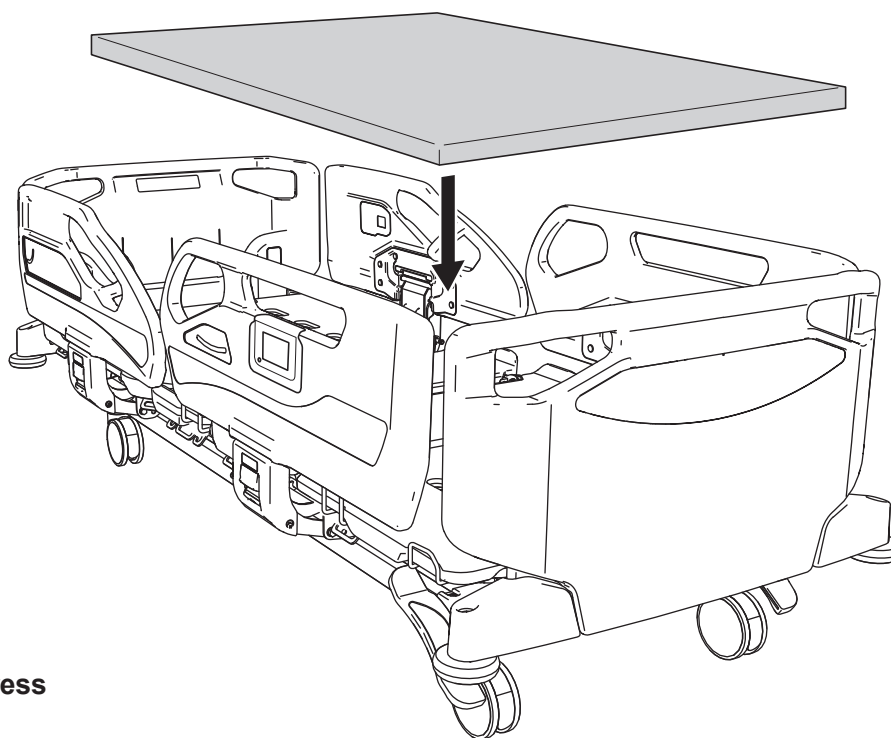

■ Suitable mattress

PE-6000 Series

PE-6013 / PE-6113 / PE-6213

PE-7000 Series

PE-7013

PE-9000 Series

PE-9013 / PE-9113

Air Mattresses cococia Fuka*1)

KE-958E / KE-968E

*1) This is not distributed in some regions where it is not registered as medical equipment.

For details on the sales of Fūka, contact Paramount Bed (see p. 122) or your distributor.



For more information about mattress specification and any queries, please feel free to contact Paramount Bed or your distributor.

3 SUITABLE PRODUCTS

3. Accessories

Handheld controller

<Part names and functions>

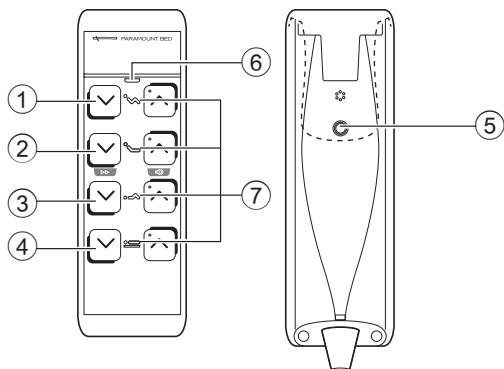

You can adjust the angle of the head and knee sections and the bed height with no increments with the handheld controller.

The handheld controller is intended to be operated by patients.

However, the function selection buttons (see p. 79 to 81) are not intended to be used by patients.

* For detaching and attaching, see p. 45 and 46.

Model No.
RC-1850E

■ Operation buttons

● To raise the part to operate, press the button, and to lower it, press the button.

- ① Head and knee coordination buttons Adjust the angle of the head/knee sections.
- ② Head buttons Adjust the angle of the head section.
- ③ Knee buttons Adjust the angle of the knee section.
- ④ Height adjustment buttons... Adjust the bed height.



- Press the operation button to operate the bed and release the button to stop the operation at its position.
- Press two or more operation and settings buttons simultaneously to stop the operation.
- If you stopped the operation by pressing two or more buttons simultaneously, remove your hands from all buttons to perform the operation again.

■ Settings button

⑤ Settings button
..... Enables you to change the various settings with the operation button.

■ Indicator lamps

⑥ Power lamp
..... Indicates the power supply status for the bed.
On (green) : Normal power on status.
Off : The power plug or handheld controller plug is disconnected, or there is a power failure or disconnection.
Flashing (orange) : Indicates a problem such as disconnection or contact with an object.
Take action in reference to "1. Troubleshooting" (see p. 98 to 101).

* The lamp also flashes green depending on the remaining power of the battery (for details, see p. 43).

⑦ Operation selection lamp
..... Indicates whether the operation button is enabled or disabled.
On (white): Operation is enabled.
Off : The power is off or the operation is disabled.

■ Display panel

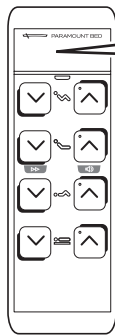

① Angle/height/error code display

..... Displays the angle of the head and knee sections and the bed height during operation. If an error code is displayed, see p. 102.

Head angle indication: -15° to 85° (displayed in increments of 1°)

Knee angle indication: -15° to 40° (indicated with a numerical value only for the upper/lower limit of the knee angles, and becomes "--" otherwise).

Height indication : 40 cm to 85 cm (indicated in increments of 1 cm)*1)

*1) If other than the 125 mm double-wheel with resin cover casters are used, the height to the mattress deck top will be higher than the indicated value. (For the exact dimensions, see the table below.)

125 mm single-wheel with resin cover	40.8 to 85.8 cm
125 mm single-wheel with iron cover (total lock)	41.3 to 86.3 cm
125 mm double-wheel with resin cover	40 to 85 cm
125 mm single-wheel with iron cover (individual lock)	41.3 to 86.3 cm
150 mm single-wheel with resin cover	43.8 to 88.8 cm



② Operation disabled state display

..... Flashes when the pressed operation button is disabled.

③ Wrench mark

..... When it is time to replace the handheld controller, the wrench mark is displayed in the setting mode. Contact Paramount Bed (see p. 122) or your distributor.

■ Identification embossing

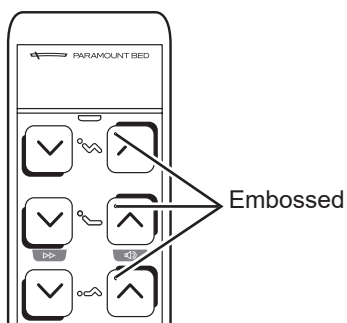

⏪ / ⏩ can be identified by touching the embossed operation buttons.

3 SUITABLE PRODUCTS

<Setting switching>

 <p>WARNING</p>	<ul style="list-style-type: none"> ● Do not allow it to be operated by a person deemed incapable of understanding the operation (a child aged 12 or under or a person with dementia). If a person deemed incapable of understanding the operation operates the handheld controller by oneself, the body may get caught in the bed by mistake, resulting in accidental injury. When such a person runs the risk of operating the handheld controller by oneself, you can use one of the following procedures to limit operation and decrease the chance of accident caused by incorrect operation. <ul style="list-style-type: none"> • Set Overall lock-out on the side-rail integrated panel to disable the operation of the handheld controller. (For the setting procedure, see p. 64.) • Set Patient lock-out on the side-rail integrated panel to disable the operation of the handheld controller. (For the setting procedure, see p. 64.) • Disconnect the power plug and turn the battery off. ● Note that if you do not press any button for 20 seconds after pressing the settings button, the settings will not be completed and return to their original settings. The bed may operate unexpectedly, resulting in injury.
---	---

■ Switching to the setting mode

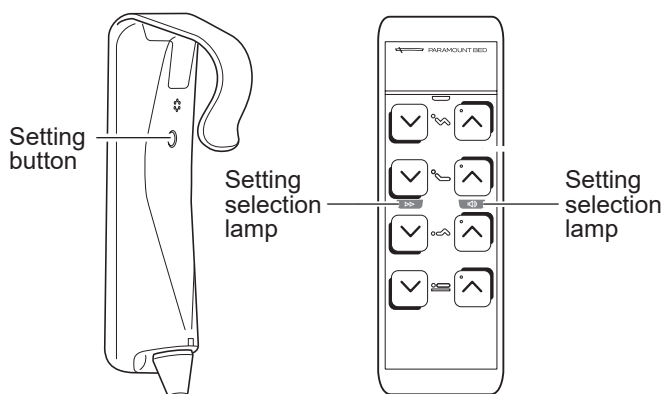

Press the settings button on the back of the handheld controller to turn on the setting selection lamp on the front, and to enable configuring various settings with the function selection buttons. When you have changed the settings, press the settings button again to confirm the settings. If you do not press the settings button, the settings will not be confirmed.

■ Function selection buttons

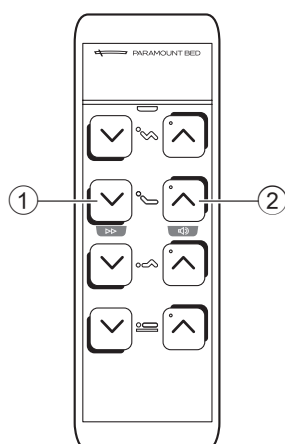

① Speed switching button [☞ p. 81]

② Operation sound button [☞ p. 81]

■ Setting each operation of the bed

You can change the settings for BED SPEED and SOUND.

● Setting BED SPEED of the head sections

You can switch BED SPEED of the head, head and knee coordination, and Cardiac Chair operations between “Normal” and “Fast.”

“Fast” operates 1.3 to 1.8 times faster than “Normal.”

* You cannot switch BED SPEED of the knee, height and Trendelenburg/reverse Trendelenburg operations. The operation speed is always “Fast.”

Brightness of the setting selection lamp

Dark: Normal

Bright: Fast



● When the bed height becomes lower than the pause height, the bed lowers at a slow speed.

● You cannot operate the Cardiac Chair and Trendelenburg/reverse Trendelenburg operations on the handheld controller.

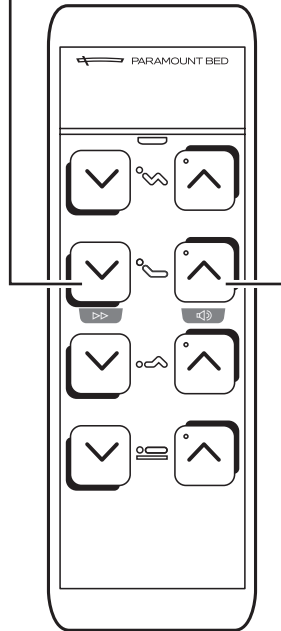

● Setting the operation sound

You can unmute or mute the operation sound that is emitted by pressing the operation button of the handheld controller.

Brightness of the setting selection lamp

Dark: Muted

Bright: Unmuted

3 SUITABLE PRODUCTS

Setting procedure

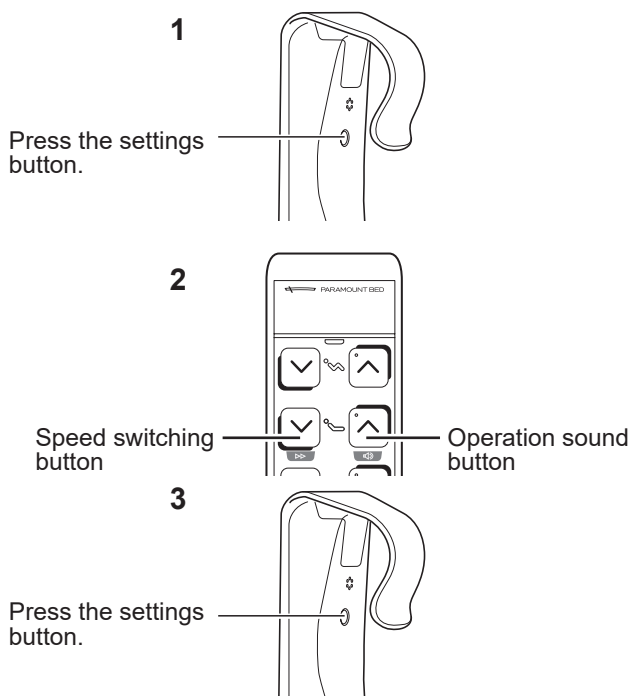

● You cannot mute the alarm sound in the following cases.

- When the height from floor to mattress deck top has reached 43 cm and the operation is stopped when lowering the bed height.
- When you are lowering the bed height again after pausing the operation.
- During electric CPR operation.

● The pause height and minimum height vary depending on the inclination of the bed.

1. Press the settings button.
2. Press the function selection button for the setting you want to change.
The setting selection lamp is switched.
3. Press the settings button.
This completes the setting.



WARNING

When the setting is completed, press the settings button on the back of the handheld controller again to confirm the setting. If you do not press the settings button, the changed setting is not confirmed and you may be injured by unexpected movement of the bed.



Settings specified using function selection buttons and in the notification function are not canceled even after a power failure or if the power plug or handheld controller plug is disconnected.

BED Navi

● The BED Navi is intended to be operated by caregivers, physicians, and nurses to perform the following bed operations.

- ① Bed positioning operation (head up, knee up, height adjustment, inclining, head and knee coordination)*¹⁾
- ② BED EXIT ALARM settings
- ③ Weight measurement cannot be set with this BED Navi.
- ④ Nemuri SCAN*²⁾ settings
- ⑤ CPR operation

You can use the BED Navi by connecting it to the handheld controller power outlet and then hooking it on the footboard with the button side facing the outside of the bed.

* For details on the attachment/detachment and operation procedures, see the instruction manual for the BED Navi.

*1) If other than the 125 mm double-wheel with resin cover casters are used, the height to the mattress deck top will be higher than the indicated value. (For the exact dimensions, see p. 117.)

*2) This is not distributed in some regions where it is not registered as medical equipment. For details on the sales of Nemuri SCAN, contact Paramount Bed (see p. 122) or your distributor.

Model No.

NS-T130AE

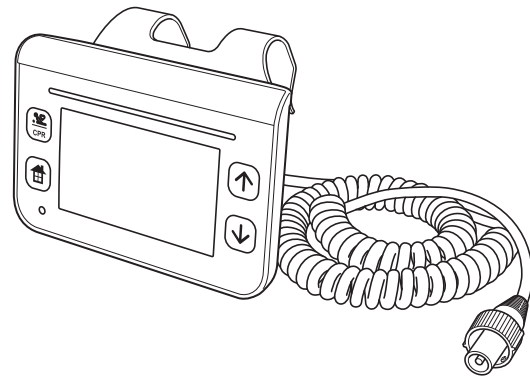
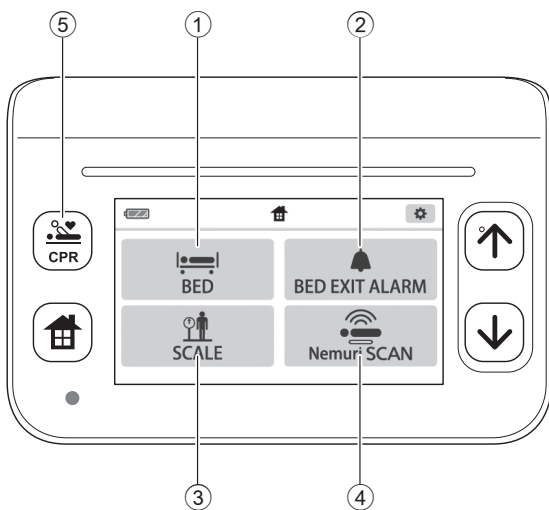

3 SUITABLE PRODUCTS

IV pole

You can hook an IV bag by attaching an IV pole.

Accessory attachment holes are located at the head end and foot end of the bed in a total of 4 locations.

Model No.

KC-56A, KC-56B, EC-562, IC-56A, IC-56B, IC-56C

* KC-56B, IC-56B and IC-56C have two hooks.

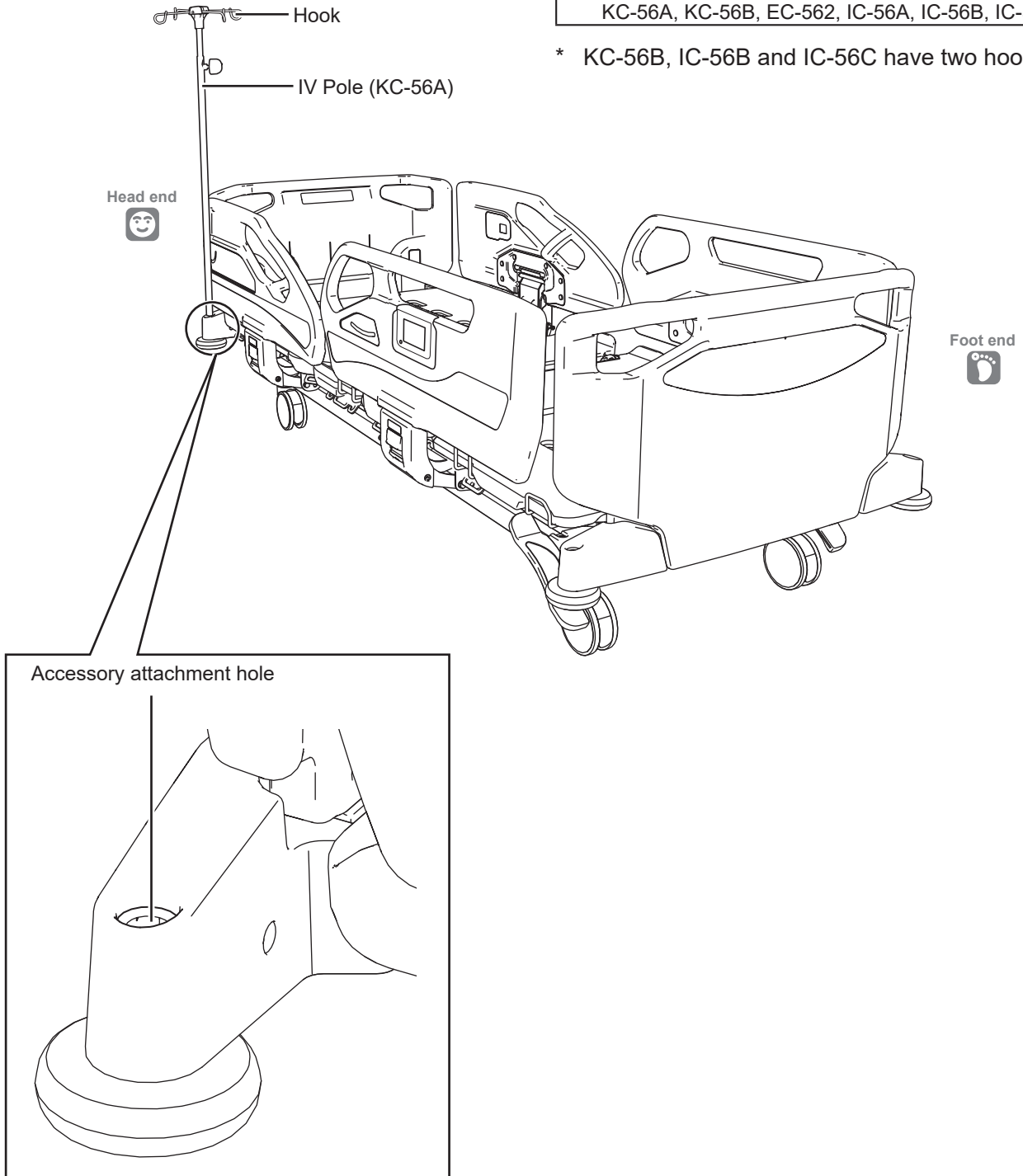

Note that the Accessory attachment hole at the foot end moves together when the extension frame is pulled out.

Oxygen cylinder holder

You can use an oxygen cylinder by attaching an oxygen cylinder holder.



<PC-5116/IC-A83>

Be sure to use a 500 L oxygen cylinder (with a diameter between 9.5 cm and 11.5 cm).

<PC-5117/PC-5038>

Be sure to use a 1,000 L oxygen cylinder (with a diameter between 14 cm and 15.5 cm).

<IC-A84>

Be sure to use a 1,000 L to 1,500 L oxygen cylinder (with a diameter between 14 cm and 15.5 cm).

Model No.
PC-5116, PC-5117, PC-5038, IC-A83, IC-A84

<PC-5116, PC-5117, IC-A83>

Accessory attachment holes are located at the head end and foot end of the bed in a total of 4 locations.

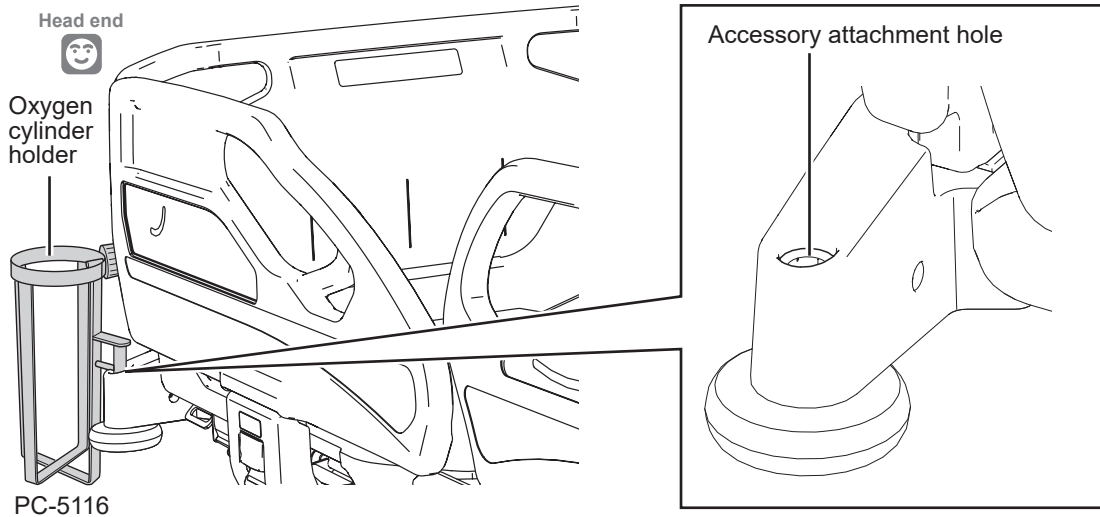

Note that the Accessory attachment hole at the foot end moves together when the extension frame is pulled out.

<PC-5038>

Hook the oxygen cylinder holder in the center of the headboard or footboard.

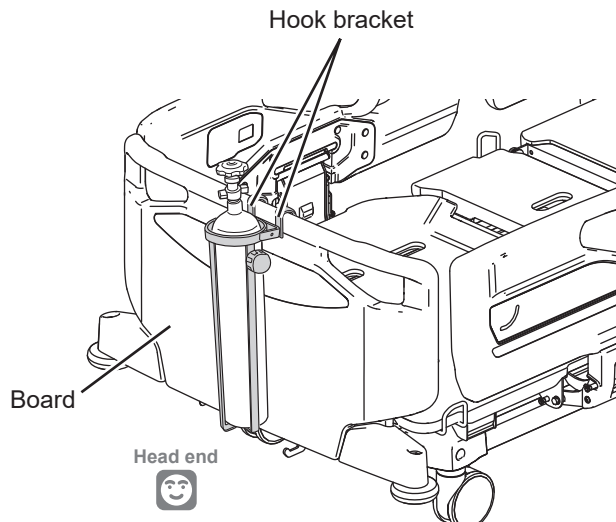

3 SUITABLE PRODUCTS

<IC-A84>

Accessory attachment holes are located at the head end of the bed in a total of 2 locations.

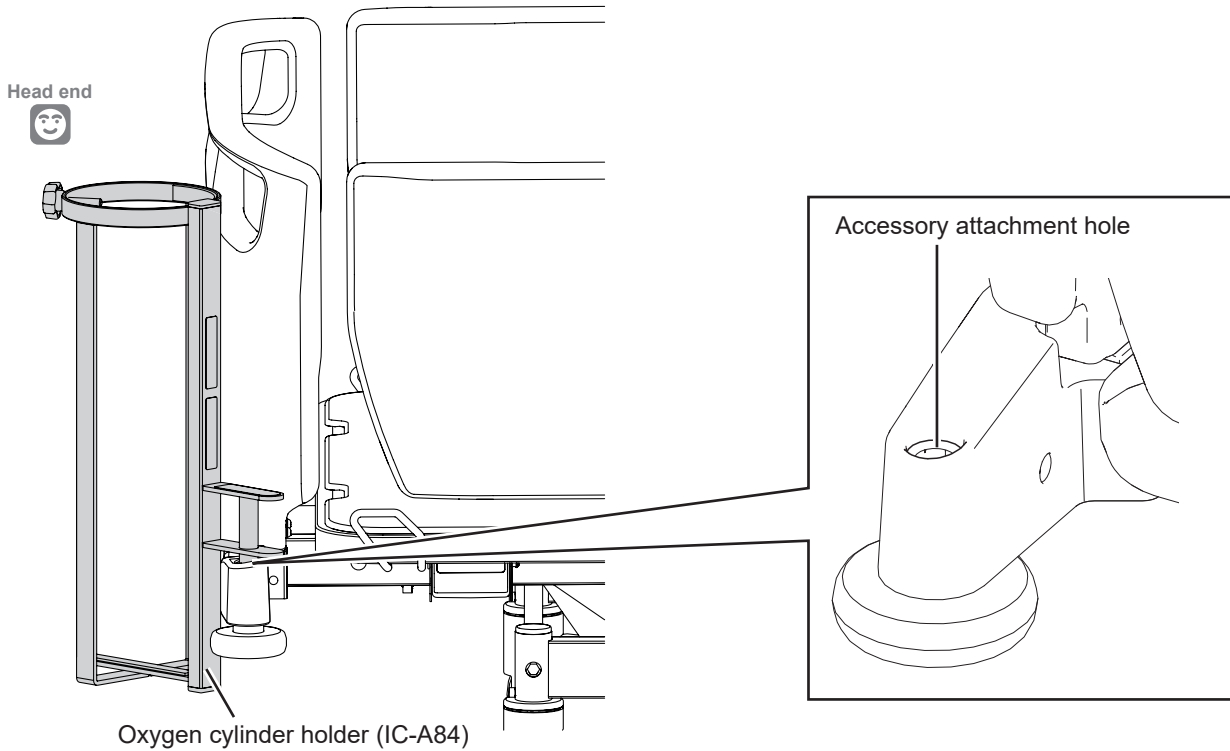

WARNING

Use the oxygen cylinder holder (IC-A84) at position A in the figure on the left. If used in position B or C, the bed may become unstable and tip over, resulting in injury.

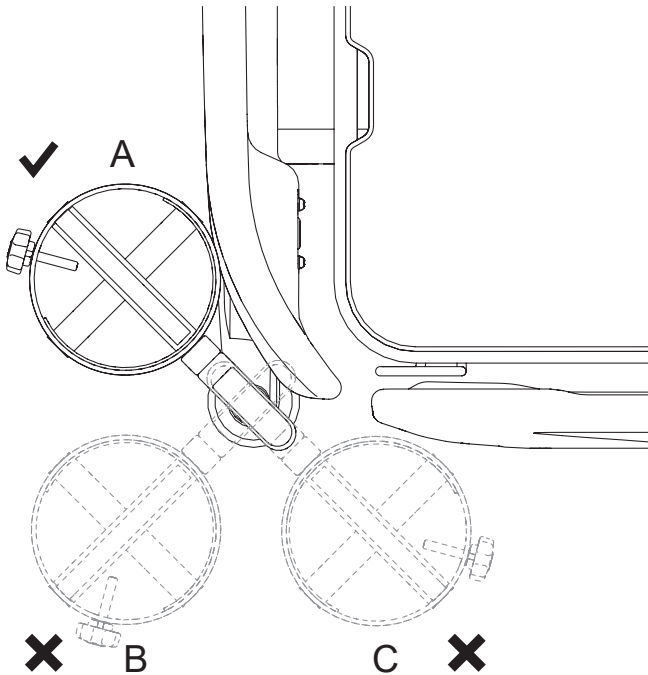

Traction frame

Insert it into the Accessory attachment hole of the bed before use.

Insert the Traction frame into the Accessory attachment hole of the bed.

* For details, see the instruction manual for the Traction frame.

* This illustration uses the KA-83U model for explanation.

Model No.
KA-83U, KA-86U*, PC-5121

* The KA-86U can be used by attaching the CA-A343 (orthopedic frame attachment) to the bed.

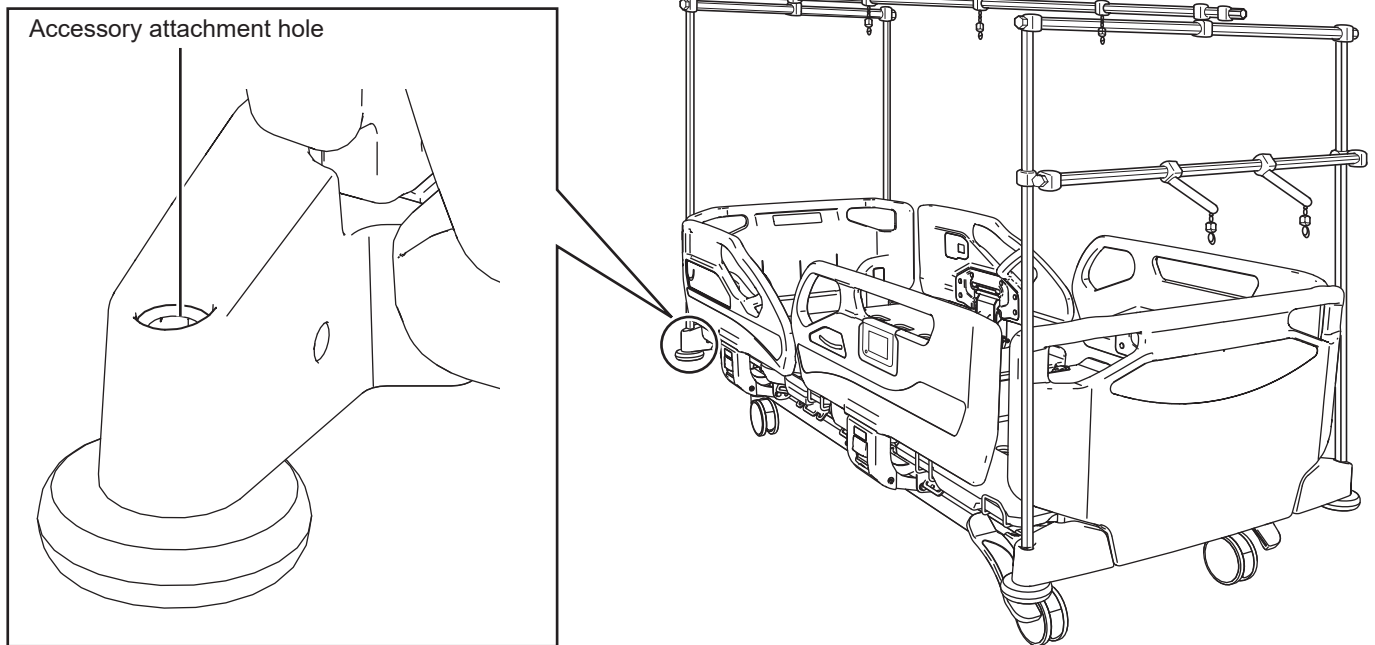

WARNING

Do not use the traction frame (KA-83U) with the extension frame drawn out. The traction frame (KA-83U) cannot be properly attached to the bed, and it may unexpectedly come off, resulting in injury, or the bed and the object may be damaged or deformed.

Orthopedic frame attachment

The orthopedic frame attachment can be used for attaching the orthopedic frame (KA-86U).

- ① Insert the orthopedic frame attachment into the Accessory attachment hole on the foot side of the bed.
- ② Insert a screwdriver into the orthopedic frame and tighten the screw.
- ③ Lightly pull up the orthopedic frame and check that it is attached firmly.

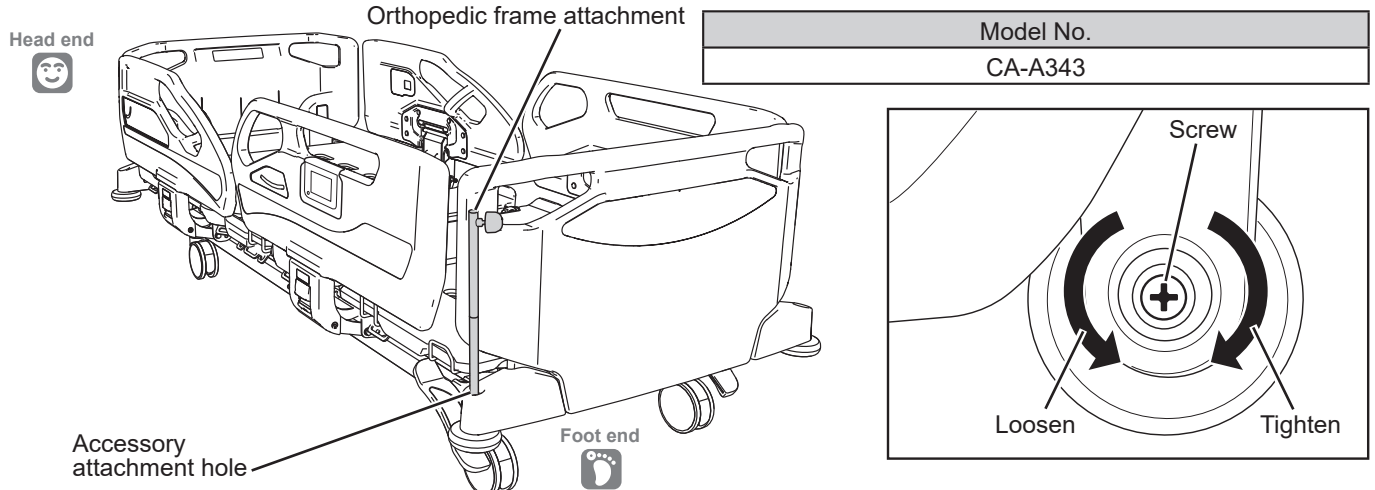

3 SUITABLE PRODUCTS

Extension mattress

The bed can be extended for tall patients by pulling out the extension frame and adding an extension mattress.

Model No.
PE-6410, PE-6420, PE-6411, PE-6421, IE-52EB, IE-52ED

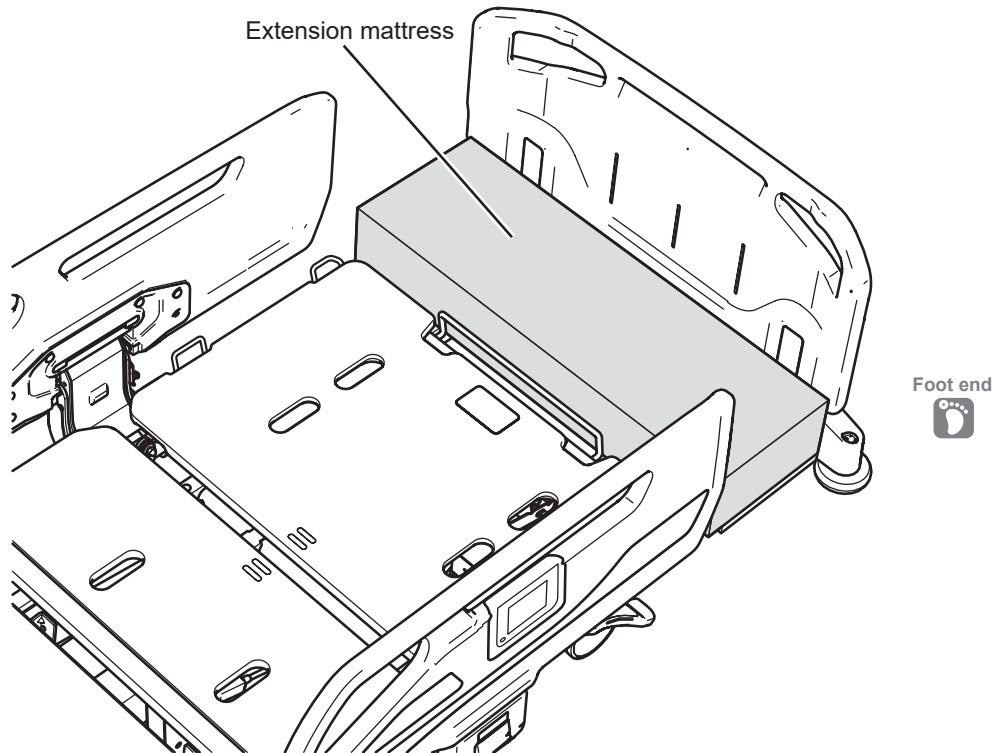

Side-rail spacer/Foot spacer (PA-H6*1*, PA-H612* only)

The gap between the footboard and side-rail created when using the extension frame can be filled in by attaching the side-rail spacer/Foot spacer.

Insert the side-rail spacer/Foot spacer into the Accessory attachment hole at the foot end before use.

* The side-rail spacer/Foot spacer is not a part of the side-rail.

Model No.
PC-5112, IC-A33321Q

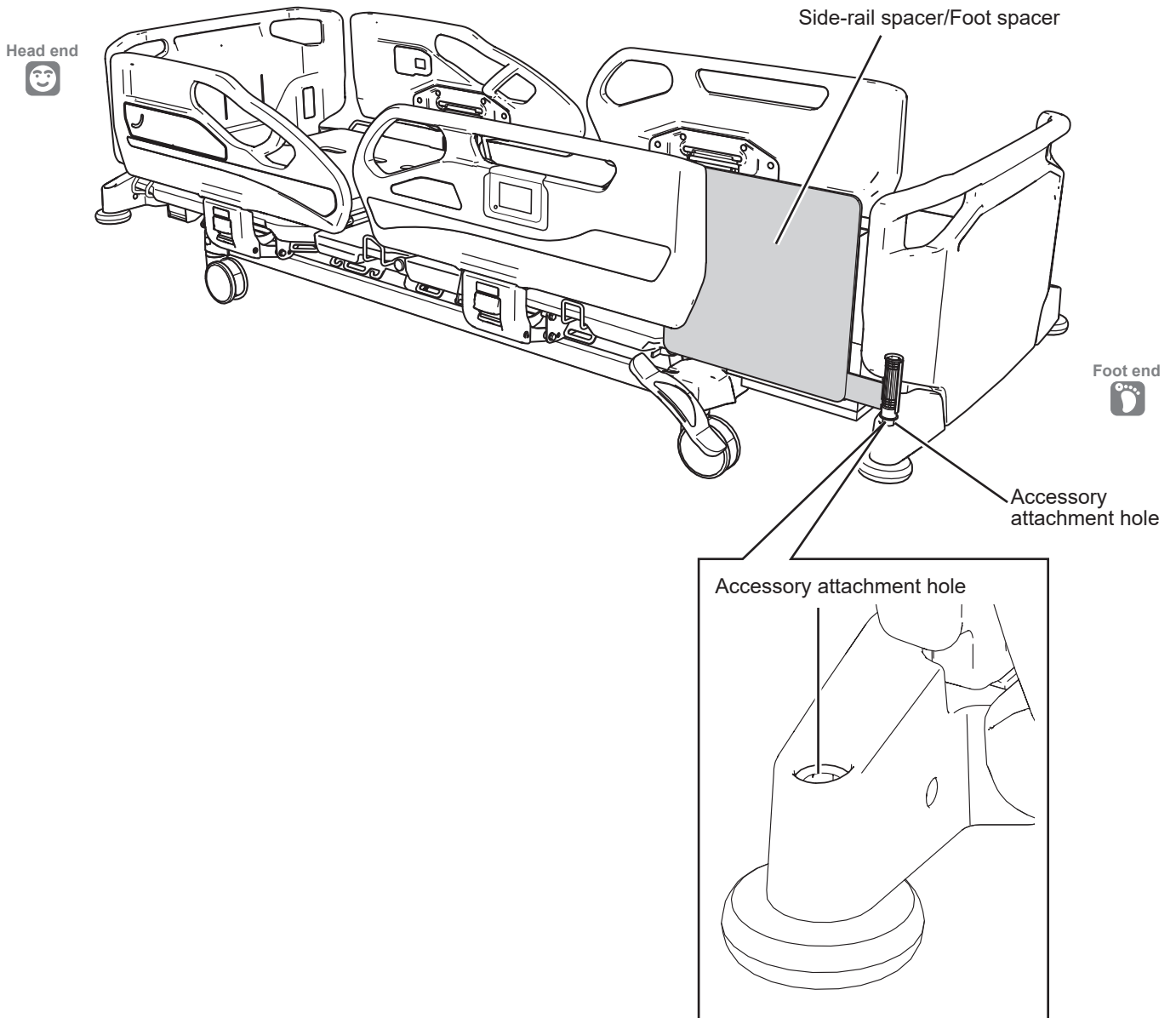

3 SUITABLE PRODUCTS

Side-rail spacer holder



CAUTION

Attach the side-rail spacer holder in the correct orientation. If attached in the wrong orientation, it may hit the patient, resulting in injury.

You can store the side-rail spacer/Foot spacer.

Hang the side-rail spacer holder on the footboard outer side.



When the side-rail spacer holder is being used, the following accessories cannot be attached to the footboard.

- Linen rack (PC-5060)
- Monitor table (PC-5119)
- Oxygen cylinder holder (PC-5038)
- Chart holder (IZ-C21CH)

Model No.

PC-5118

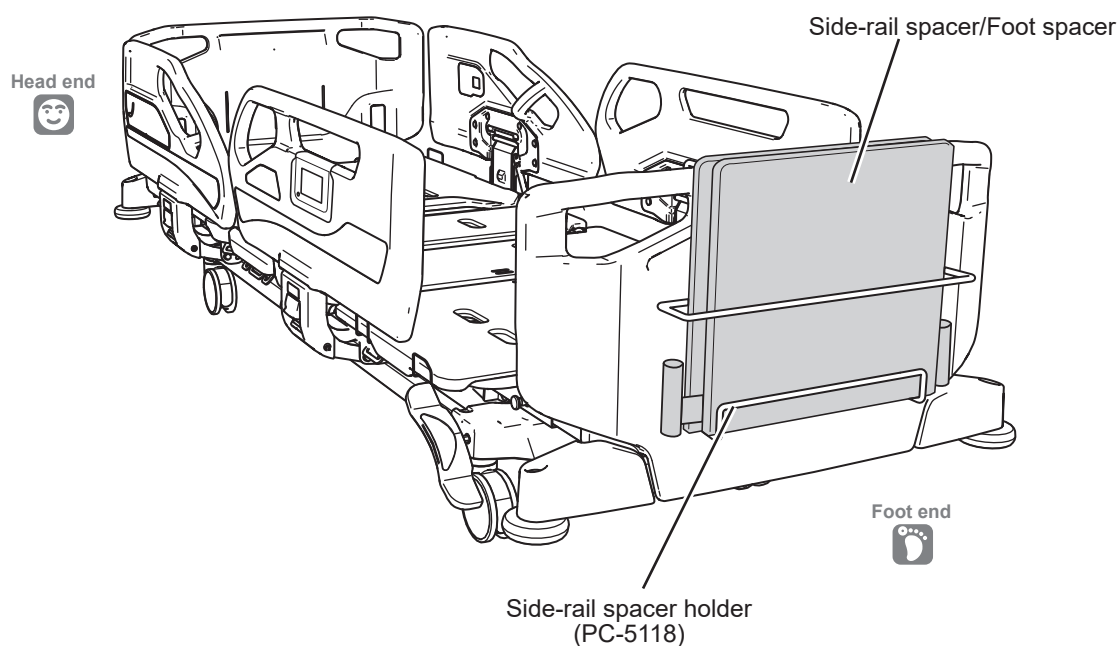

Lifting pole

Model No.

PC-5111



WARNING

- Load capacity is 76 kg. Do not hang an article exceeding the load capacity because it may damage the lifting pole, resulting in injury.
- During transportation, do not hang on to the lifting pole. It may tip over the bed, the patient on the bed may fall off the bed, resulting in injury.

■ The lifting pole can be used for support to raise the body from the bed by attaching to the bed. It can be used for training too.

1. Attach the parts of the lifting pole to the bed as shown in figure.
2. Inset the arm into the outer pipe.
3. Tighten the knob bolt to fasten the arm. The arm can be set in three positions as shown in figure by changing the knob bolt positions.
4. Pull down the grip to make sure that the lifting pole is attached firmly.

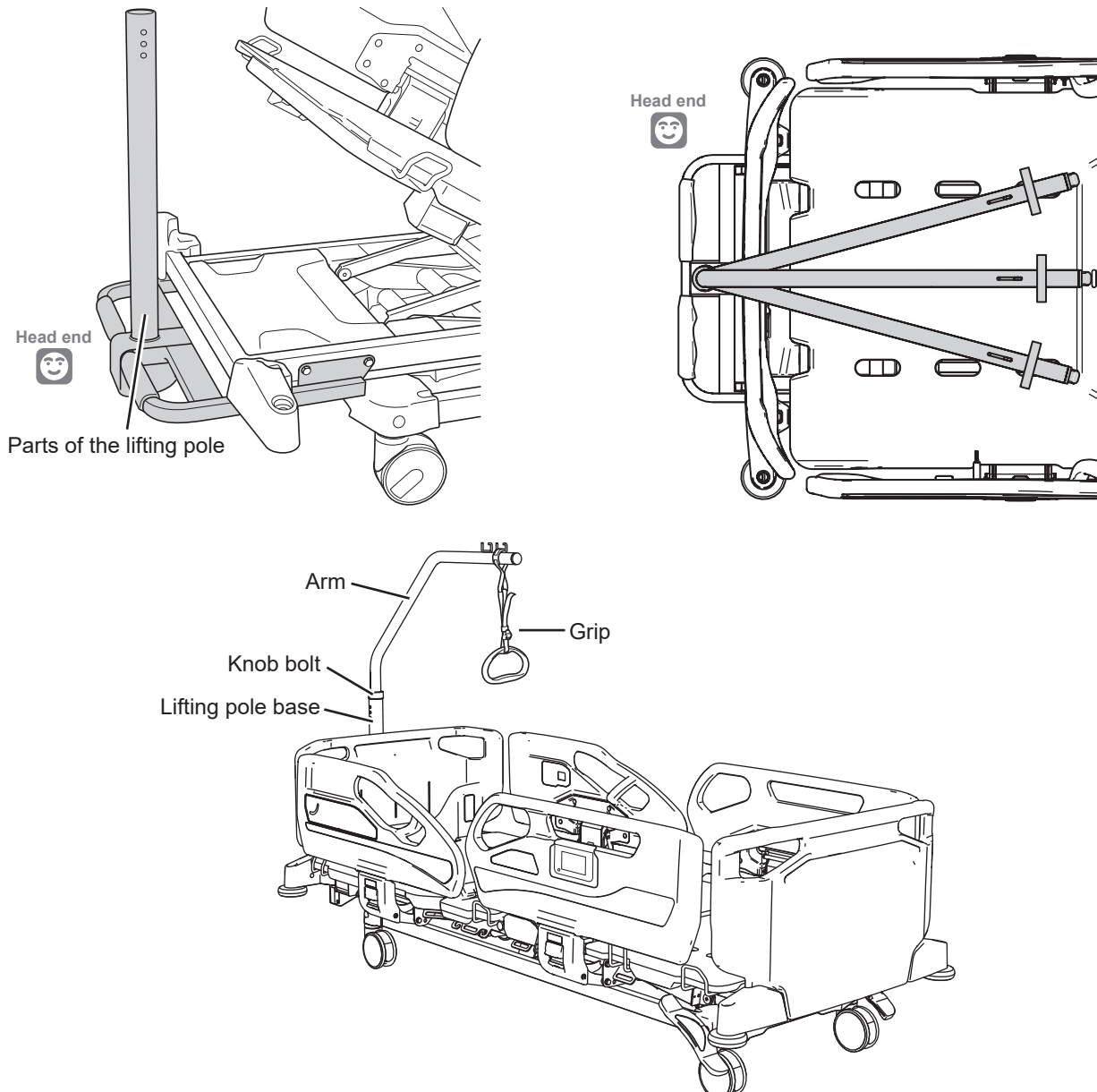

3 SUITABLE PRODUCTS

Monitor table

- You can attach the monitor table to the footboard of the A6 Series and use it as a table to place a monitor.

 WARNING	<ul style="list-style-type: none">● Do not place an object exceeding 12 kg on the monitor table. The monitor table or bed may be damaged or deformed resulting in injury, or the placed object may be damaged or deformed.● When an overbed table is placed over the bed, do not place an object on the monitor table. The object may fall, resulting in injury or in damage to the object.
--	--

 CAUTION	Attach the monitor table in the correct orientation. If the monitor table is lowered when in the wrong orientation, it may hit the patient, resulting in injury.
--	--



When the monitor table is being used, the following accessories cannot be attached to the footboard.

- Side-rail spacer holder (PC-5118)
- Linen rack (PC-5060)
- Oxygen cylinder holder (PC-5038)
- Chart holder (IZ-C21CH)

Model No.

PC-5119

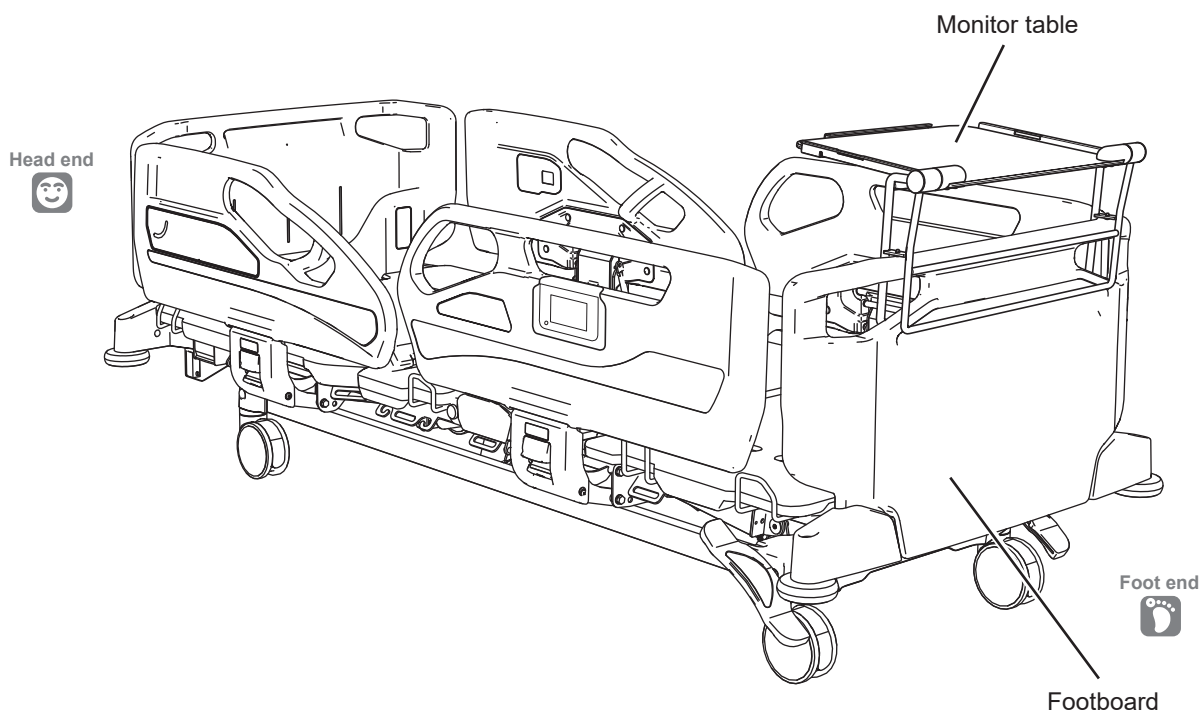

Drain bag holder

You can hang drain bags on the drain bag holders.

The drain bag holders are located one each on the left and right at the head end of the bed (2 locations in total).

Model No.

PC-5120

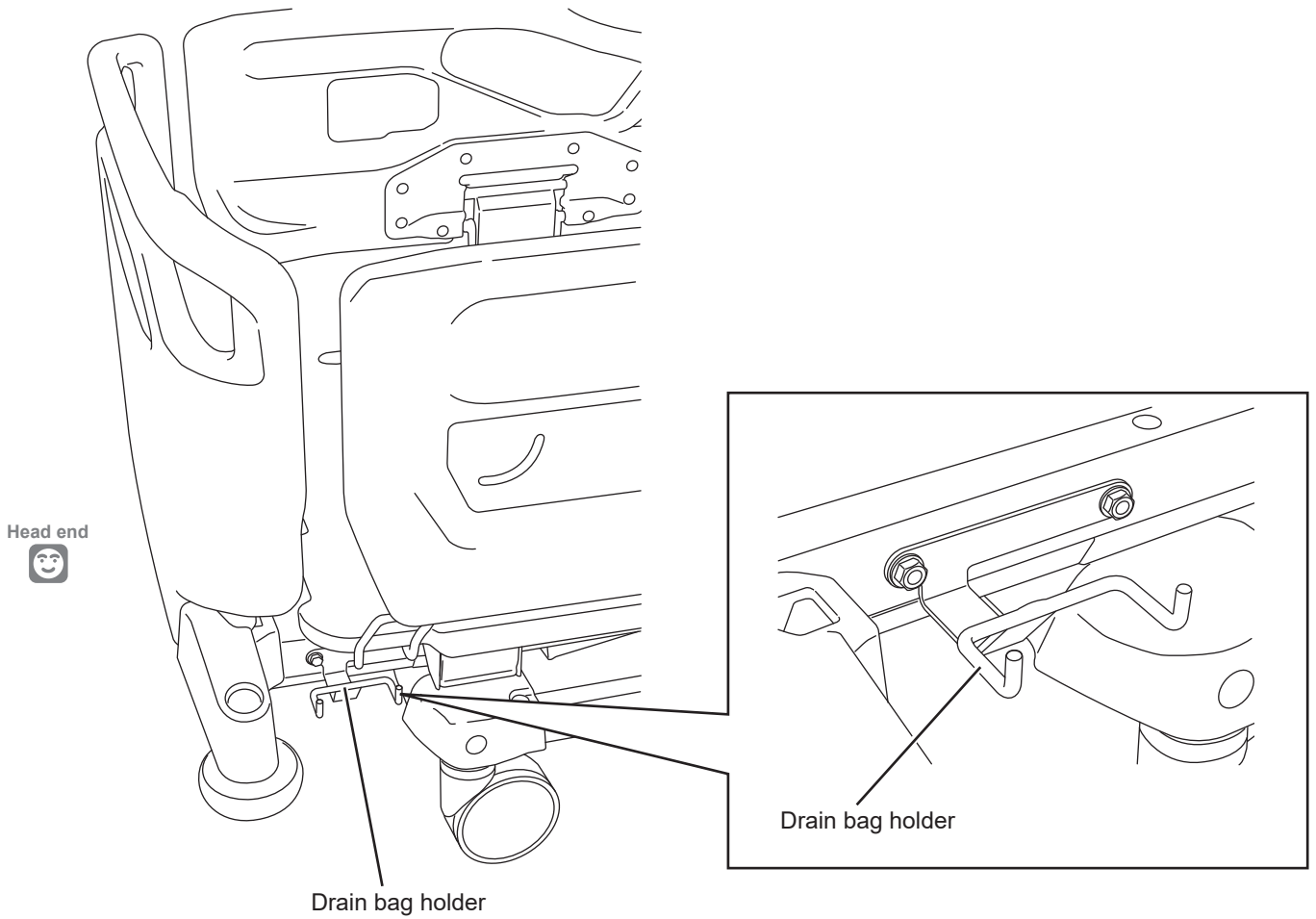

3 SUITABLE PRODUCTS

Bed linen rack

Model No.

PC-5060



CAUTION

- Load capacity is 1 kg. Do not set an article exceeding the load capacity because it may cause the linen rack to be damaged or deformed.
- Attach the bed linen rack in the correct orientation. If attached in the wrong orientation, the rack may hit the patient, resulting in injury.

■ The bed linen rack can be used for setting the linen temporarily when bedmaking.

1. Hang the bed linen rack on the footboard with the rack facing the outside of the bed.
2. When using the bed linen rack, pull the rack out.
3. After using the bed linen rack, push the rack to the clip.

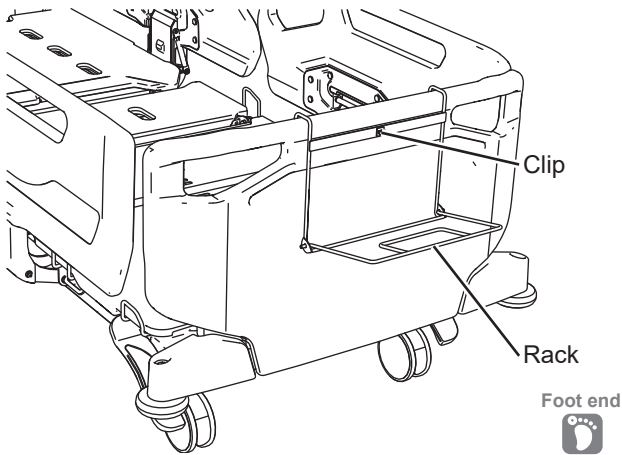

Using the bed linen rack

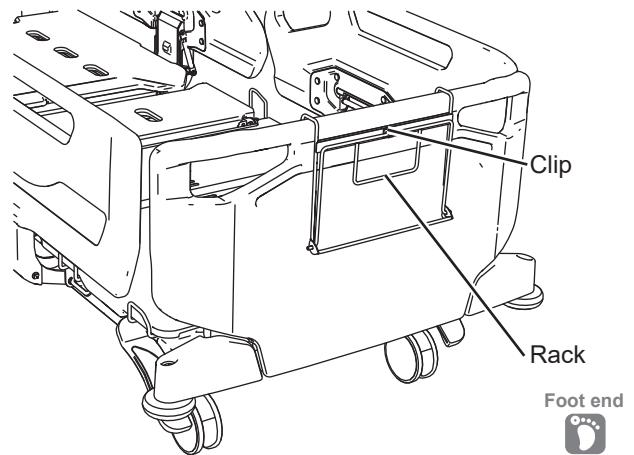

Storing the bed linen rack



When the bed linen rack is being used, the following accessories cannot be attached to the footboard.

- Side-rail spacer holder (PC-5118)
- Monitor table (PC-5119)

Chart holder



WARNING

- Load capacity is 1 kg. Do not set an article exceeding the load capacity because it may cause the chart holder to be damaged or deformed.
- Attach the chart holder in the correct orientation. If attached in the wrong orientation, the rack may hit the patient, resulting in injury.

■ The chart holder can be used for setting the charts.

1. Hang the chart holder on the footboard with the holder facing the outside of the bed.



When the chart holder is being used, the following accessories cannot be attached to the footboard.

- Side-rail spacer holder (PC-5118)
- Monitor table (PC-5119)
- Bed linen rack (PC-5060)

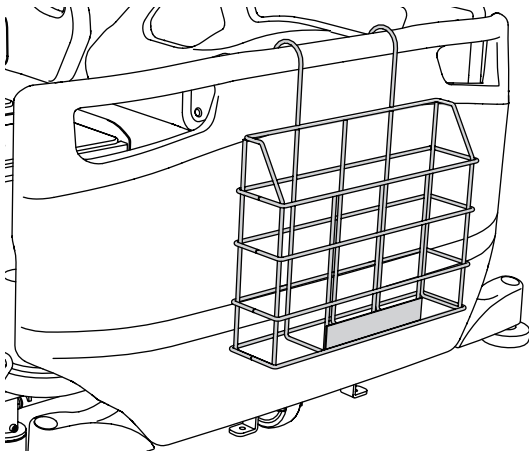

Model No.

IZ-C21CH

3 SUITABLE PRODUCTS

4. Peripherals

Bedside table

The bedside table is used for having meals or doing easy chores on the bed.

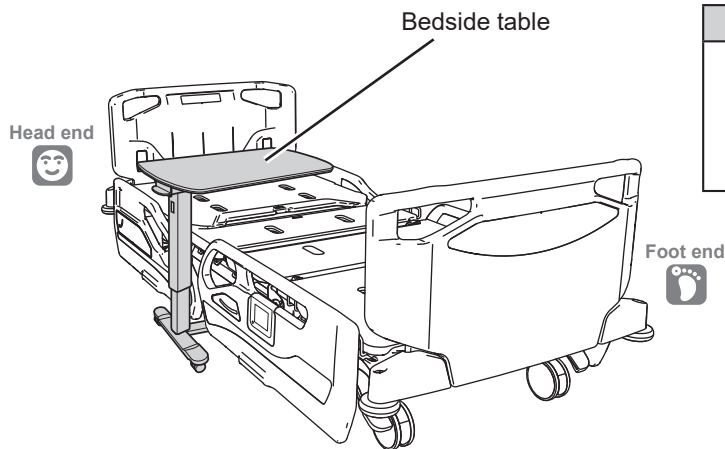

Model No.
KF-1900, KF-1920, KF-1930, KF-1950, KF-1960, KF-1970, KF-1924, KF-1934, KF-1954, KF-1964, KF-1974, KF-282A, PF-3100A, PF-3110A, PF-3120A, PF-3130A

WARNING

- Do not perform bed operations when the bedside table is placed on the side of the bed. If you perform bed operations such as head up or height adjustment, you may get caught between the bed and bedside table resulting in injury, or the bedside table or bed may be damaged or deformed.
- When moving the bedside table around the bed, be careful to prevent the bedside table from hitting the side pedal. The bed may operate unexpectedly, resulting in accidental injury.
- The following figure shows the usage range of the bedside table. ( cannot be used.) If it is used anywhere outside the range shown in the figure below, the casters of the bed may be unlocked and the bed may move unexpectedly, resulting in accidental injury. The bedside table may be damaged or deformed.

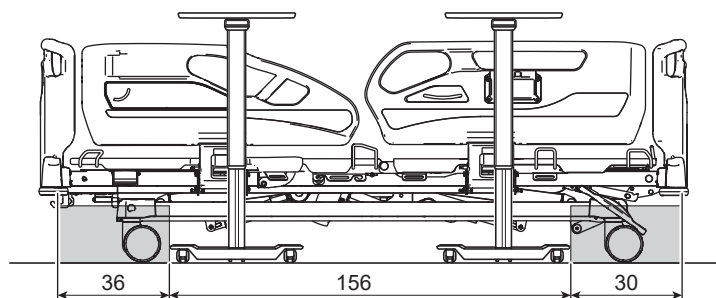

Unit: cm

125 mm caster



Note When side-rails are raised, you cannot use the bedside table in the vicinity of the maximum bed height.

Overbed table

The overbed table is used for having meals or doing easy chores on the bed.

Model No.
KF-832LA/LB/LC, KF-833LA/LB/LC, KF-835LA/LB/LD, KF-813

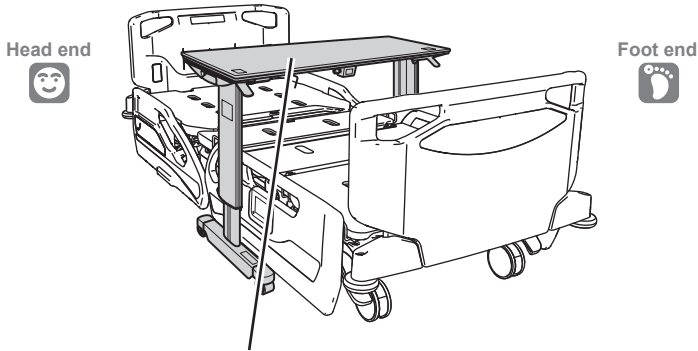

Overbed table

Sittan™

You can use the Sittan™ to support the sitting position of a patient on the bed side who cannot maintain a sitting position without assistance.

Model No.
KF-890, KF-840

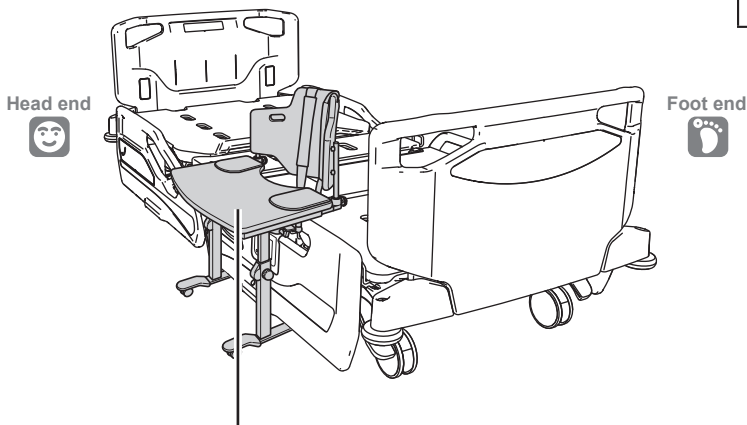

Sittan™ (KF-890)

3 SUITABLE PRODUCTS

Electric patient lift (floor traveling)*1)

You can use the floor traveling electric patient lift ("lift") shown on the right.

Model No.
KQ-781, KQ-787

*1) The lift is not sold in some countries or regions. Also, it may be classified as medical equipment. For details, contact PARAMOUNT BED CO., LTD. (see p. 122) or your distributor.



WARNING

- Also read the instruction manual supplied with the lift. Improper use may result in accidental injury.
- When operating the bed and the lift, be careful around the lift.
 - A body part may get caught between the bed and hanger or hit the hanger, resulting in injury.
 - The boom or hanger may hit a person resulting in injury, or hit the bed or furniture, causing damage.
 - The hanger hook may get caught in the side-rail and the lift or side-rail may be damaged or deformed.
 - The bed may hit the foot of the lift or the actuator, causing damage or deformation.
- Do not lock the casters of the lift when the foot of the lift is inserted under the bed. If the bed hits the foot of the lift or the actuator during bed operation, the lift may fall over resulting in injury, or the bed or lift may be damaged or deformed.
- When inserting the foot of the lift under the bed, do not step on or run over the power cable. The power cable may be damaged, resulting in electric shock or fire.
- When moving the lift around the bed, be careful to prevent it from hitting the side pedal of the bed. The casters may be unlocked and the bed may move unexpectedly when getting into or out of the bed, resulting in accidental injury.



CAUTION

Do not use the lift below the pause height. The foot of the lift may come into contact with the side-rail and the lift and side-rail may be damaged or deformed.

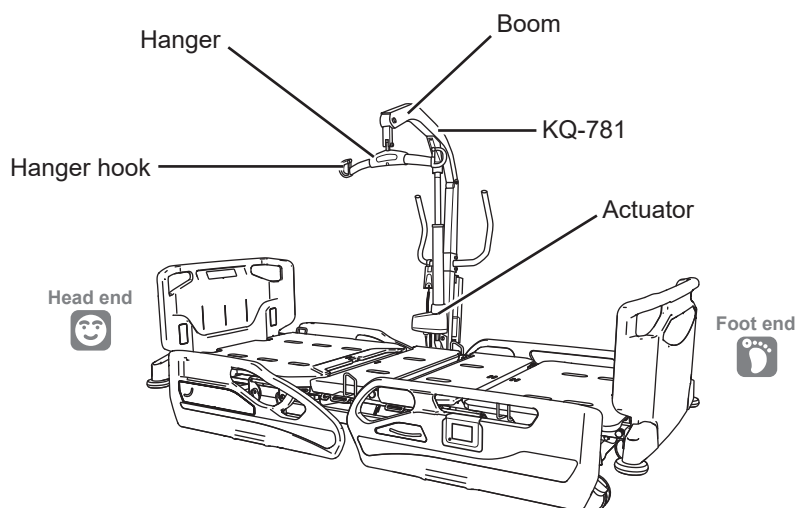

4 IN CASE OF TROUBLE

1. Troubleshooting

- Problems may not always indicate faults. Check the following once again before requesting repair.
- If the problem persists after taking corrective action, stop using the bed immediately, disconnect the power plug from the outlet, turn the battery off, and then contact Paramount Bed (see p. 122) or your distributor for repair.
- If the bed is damaged in an earthquake, fire, flood, or any other incident, contact Paramount Bed (see p. 122) or your distributor for inspection or repair. Electric shock or fire may occur due to a short circuit or current leakage from electrical components or malfunction may occur due to deformation of the bed, resulting in injury.
- If a failure or error occurs, an error code may be displayed on the DS display panel, the display panel of the handheld controller (accessory), and the touch panel of the BED Navi (accessory). Check the error code. (See p. 102)

Symptoms and status	Check	Corrective action	Reference page
Buttons do not work on the side-rail integrated panel, patient control panel, or handheld controller (accessory).	Is the power plug inserted into the outlet?	Insert the power plug into the outlet.	40
	The power plug is inserted into the outlet but the bed still does not operate.	<ul style="list-style-type: none"> • Disconnect the power plug from the outlet and insert it in again. • Plug another electrical device into the outlet and check that power is available. 	40
	Is Patient lock-out set on the side-rail integrated panel?	Disable Patient lock-out on the side-rail integrated panel.	64
	Are two or more handheld controllers (accessory) plugged into the handheld controller power outlets?	If two or more handheld controllers (accessory) are plugged into the handheld controller power outlets, the bed does not operate. Insert only one.	45•46
The power lamp on the handheld controller (accessory) is off.	Is the power plug inserted into the outlet?	Insert the power plug into the outlet.	40
	The power plug is inserted into the outlet, but the power lamp on the handheld controller (accessory) is off.	<ul style="list-style-type: none"> • Disconnect the power plug from the outlet and insert it in again. • Plug another electrical device into the outlet and check that power is available. 	40
	Is the handheld controller (accessory) plug disconnected from the handheld controller power outlet?	Insert the handheld controller (accessory) plug into the handheld controller power outlet.	45•46
Parts cannot be positioned correctly.	Are there objects in the moving parts?	Remove any objects.	—
The bed cannot be moved.	Are the casters locked?	Unlock the casters.	33
Board cannot be detached.	Is the board locked?	Unlock the board.	28
Call is not made even when the nurse call auxiliary button is pressed.	Is the power plug inserted into the outlet?	Insert the power plug into the outlet.	40
	Is the bed communication cable disconnected from the bed or the nurse call wall plate?	Firmly connect the bed communication cable.	47
	Are the nurse call system and bed communication cable suitable for the bed?	For details on the suitable nurse call system and suitable bed communication cable, contact Paramount Bed (see p. 122) or your distributor.	—

4 IN CASE OF TROUBLE

Symptoms and status	Check	Corrective action	Reference page
Notification is not made even though, for example, the patient is out of bed.	Is the power plug disconnected?	Insert the power plug into the outlet. If the power plug is not inserted into the outlet, you cannot use BED EXIT ALARM.	40
	Is the relay unit connected with the cable properly?	Connect the cable properly while referring to the instruction manual for the relay unit.	—
	Is the bed communication cable disconnected from the bed or the nurse call wall plate?	Firmly connect the bed communication cable.	47
	Are the nurse call system and bed communication cable suitable for the bed?	For details on the suitable nurse call system and suitable bed communication cable, contact Paramount Bed (see p. 122) or your distributor.	—
	Is the notification lamp on the relay unit lit?	Turn on notification on the relay unit.	*
	Is the power lamp of the DS display panel or BED Navi (accessory) flashing orange?	Check the error code and then take corrective action.	102
	Are there any obstacles between the bed and floor?	Remove any objects.	—
	Is the weight of the patient 30 kg or more?	BED EXIT ALARM is intended to be used for a user of at least 30 kg, so a user less than 30 kg may not be detected.	*
	Is the weight set according to the weight of the patient?	Set the weight according to the weight of the patient.	
	Are the notification settings configured properly?	Configure the notification settings properly.	*
	Is the "MONITORING" function selected?	If "MONITORING" is selected, notification is not made when the patient gets out of the bed, sits down on the edge of the bed, or sits up.	55
	Did the patient take an action such as getting out of the bed during bed operation?	Notification is not made during bed operation even when the patient gets out of the bed or sits up. If you consider that the patient may get into or out of the bed during bed operation, set Overall lock-out.	64
	Did the patient get out of the bed or sit up slowly?	If it takes 4 minutes or more for the patient to get out of the bed or sit up, notification may not be made.	53
Did the patient get out of the bed or sit up after a heavy object was placed on the bed?	If the patient gets out of the bed or sits up on the bed after a heavy object (which weighs more than half the patient's weight) was placed on the bed, notification may not be made.		
Notification is not made even though the patient is sitting on the edge of the bed.	Is the patient sitting on the edge of the bed and applying body weight to the floor?	If body weight is not applied to the floor, notification may not be made.	55
Notification is not made even though the patient sat up (type with BED EXIT ALARM only).	Is the patient's sit-up motion significant enough?	If the patient's upper body motion is insignificant, notification may not be made. This is not a failure. If notification is not made even though the patient raises the upper body to some extent, turn off notification once and then turn it on again.	*
	Did the patient sit up while his or her head is positioned at the foot end of the bed?	If the patient sat up while his or her head is positioned at the foot end of the bed, detection may not work. After getting the patient to lie down with his or her head positioned at the head end of the bed, turn off notification once and then turn it on again.	53 and *
	Did the patient sit up by propping themselves up with a hand or elbow at the head end of the bed?	If the patient sits up by propping themselves up with a hand or elbow at the head end of the bed, notification may not be made.	53

*) For the settings of BED EXIT ALARM, see "Connecting the bed communication cable" (p. 47) or the instruction manual for the relay unit.

Symptoms and status	Check	Corrective action	Reference page
Notification is made even though the patient did not perform actions such as getting out of the bed (type with BED EXIT ALARM only).	Are the notification settings configured properly?	Configure the notification settings properly.	*
	Is an object of 3 kg or more removed from the bed?	If an object of 3 kg or more is removed from the bed, notification may be made. In such a case, turn off or pause notification.	54 and *
	Did a person other than the patient get into or out of the bed?	If a physician, nurse, or visitor gets on or out of the bed, notification may be made. In such a case, turn off or pause notification.	
	Is a board detached?	If a board is detached, notification may be made. In such a case, turn off or pause notification.	
	Is weight applied to the footboard?	If weight is applied to the footboard, notification may be made. In such a case, turn off or pause notification.	54
	Is the angle of the head section large?	The larger the angle of the head section is, the higher is the possibility that the SIT-UP detection function makes notification with a slight movement even though the patient does not sit up.	
Notification is made earlier than the specified monitoring time.	Was the monitoring time setting changed while the patient is out of bed?	Turn off notification and then set the monitoring time again while the patient is lying on the bed.	*
The weight is not displayed.	—	Disconnect the power plug from the outlet, turn the battery off, check that the power lamp on the DS display panel is turned off, and then insert the power plug back into the outlet.	40
Charging of the USB device does not start or charging stops prematurely.	Is the power plug inserted into the outlet?	Insert the power plug into the outlet.	40
	Is charging with the AC adapter for USB devices possible?	The charge current may be insufficient or the bed may not be suitable for the USB device. Disconnect the USB device from the USB port and charge it with an AC adapter for USB devices.	—
Although the USB device is being charged, the remaining battery power does not increase or charging takes a long time.	Does the USB device operate?	The charge current may be insufficient or the bed may not be suitable for the USB device. Disconnect the USB device from the USB port and charge it with an AC adapter for USB devices.	—

*) For the settings of BED EXIT ALARM, see “Connecting the bed communication cable” (p. 47) or the instruction manual for the relay unit.

If you request repair or if you have any questions, please provide us with the number displayed on the product ID label.

4 IN CASE OF TROUBLE

■ Positions of product ID labels

Product ID labels are affixed to the right side of the main frame and on the inside of the footboard.

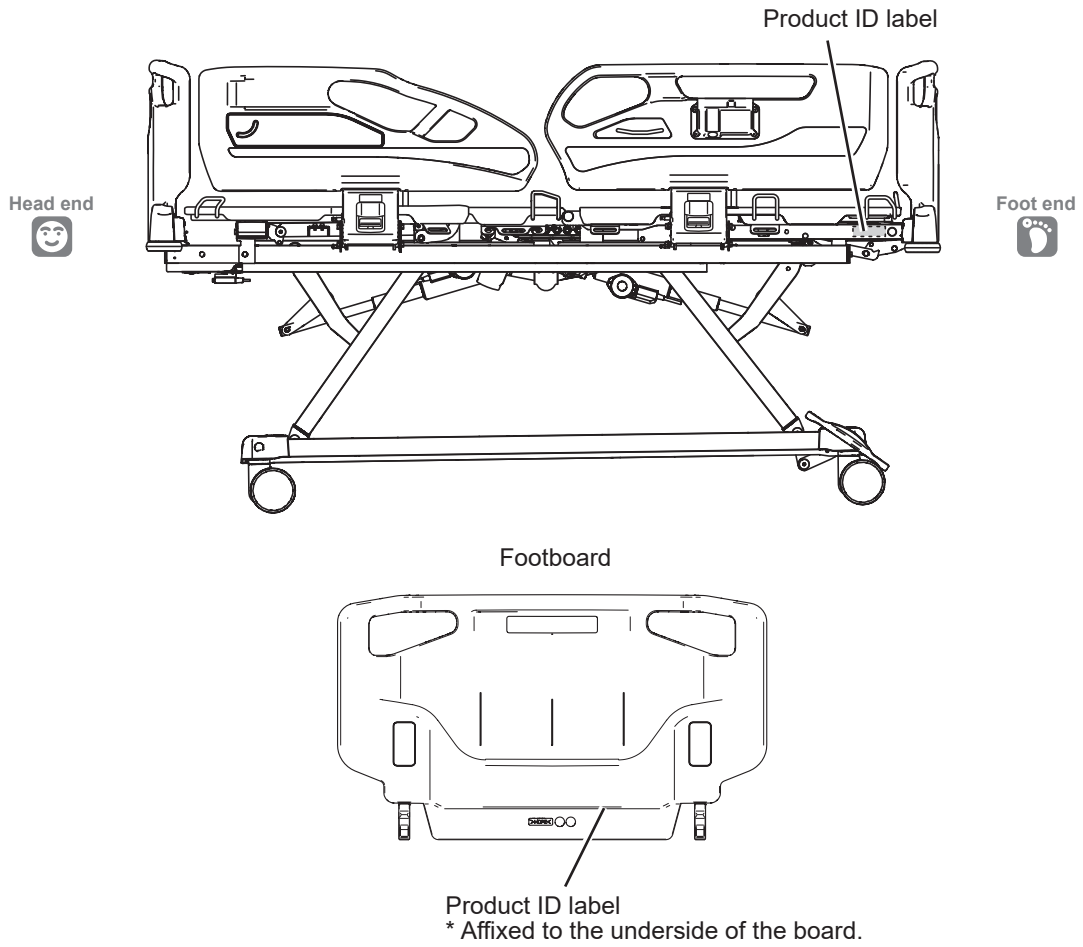

2. Error codes

Error code list

If a failure occurs, an error code may be displayed on the DS display panel, the display panel of the handheld controller (accessory), and the touch panel of the BED Navi (accessory). Check the error code.

<Bed operation>

Problem	Power lamp flashing rate	Error code	Cause	Corrective action	
Pressing a button on the DS display panel, BED Navi (accessory), or handheld controller (accessory) causes the power lamp to flash orange.	Slow flashing orange (1-second interval)	U0	You are holding down an operation button when turning on the power.	Release the button you are holding down.	
		U1	The load on the bed exceeded the safe working load.	Check that the load on the bed is within the safe working load.	
			Operation of the bed is restricted by an obstacle, etc.	Make sure that operation of the bed is not restricted by an obstacle, etc.	
		U2	A communication error is occurring.		Check the cable for scratches and other damage.
					Fully insert the plug of the DS display panel, BED Navi (accessory), or handheld controller (accessory) cable.
					Before using equipment such as electronic medical equipment, disconnect the power plug of the bed from the outlet.
					If the plug of the DS display panel, BED Navi (accessory), or handheld controller (accessory) is wet, dry it and then insert it back into the outlet.
		U3	The load on the bed exceeded the safe working load.		Check that the load on the bed is within the safe working load.
					Make sure that operation of the bed is not restricted by an obstacle, etc.
			The bed is operating for a long time intermittently.	Wait for 20 to 38 minutes and then check the operation. If the error code is displayed again, contact Paramount Bed or your distributor.	
A bed operation button is held down while operating the CPR lever.	Release the operation button you are holding down.				
U4	A bed operation exceeded the maximum continuous operating time.	Wait for 20 to 38 minutes and then check the operation. If the error code is displayed again, contact Paramount Bed or your distributor.			
U5	An error with the actuator cable is occurring.	Turn the power back on and then check the operation. If the error code is displayed again, contact Paramount Bed or your distributor.			
U9	You are holding down a button.	Release the button you are holding down.			
The power lamp on the DS display panel, BED Navi (accessory), or handheld controller (accessory) is flashing orange all the time.	Fast flashing orange (0.2-second interval)	H0	There is a possibility that a sensor for the BED EXIT ALARM has failed.	Turn the power back on and then turn on notification for the BED EXIT ALARM. If the error code is displayed again, contact Paramount Bed or your distributor.	
		H1/H4 H5/H7	There is a possibility that the control box has failed.	Turn the power back on and then check the operation. If the error code is displayed again, contact Paramount Bed or your distributor.	
		H2	There is a possibility that the control box has failed.	Check that the load on the bed is within the safe working load. If the load on the bed is high, reduce the load and turn the power back on, and then check the operation. If the error code is displayed again, contact Paramount Bed or your distributor.	
		H3	There is a possibility that the actuator has failed.	Check that the load on the bed is within the safe working load. If the load on the bed is high, reduce the load and turn the power back on, and then check the operation. If the error code is displayed again, contact Paramount Bed or your distributor.	
		H8	There is a possibility that the control box has failed.	If the error code is displayed also after turning the power back on, contact Paramount Bed.	



If the problem persists after taking the corrective action above, contact Paramount Bed (see p. 122) or your distributor.

4 IN CASE OF TROUBLE

<SCALE>

Problem	Power lamp flashing rate	Error code	Cause	Corrective action
The power lamp on the DS display panel or BED Navi is flashing orange all the time.	Slow flashing orange (1-second interval)	S01/S06	There is a possibility that a load cell has failed.	If the error code is displayed also after turning the power back on, contact Paramount Bed.
		S02/S03	The weight on the bed exceeded the measurement range.	Check that the load on the bed is within the safe working load.
		S04	The load on the bed is too low.	Check that the boards and mattress deck are attached and there are no obstacles under the bed.
The weight is not displayed in the SCALE screen.	—	S05	The BED Navi is attached to a bed other than the tested one.	Attach it to the correct bed. If it is attached to a bed other than the tested one, the weight cannot be displayed.



If the problem persists after taking the corrective action above, contact Paramount Bed (see p. 122) or your distributor.

5 REFERENCE INFORMATION

1. Regular inspection and daily maintenance

Regular inspection

To ensure safety, inspect the product regularly, at least once a year. The product wears out and deteriorates differently depending on the operating frequency and environment. Inspect for loose parts and damage and the operation of the moving parts regularly.

If you notice an irregularity or want a detailed inspection, contact Paramount Bed (see p. 122) or your distributor.

Part	Operation	Inspection item
Bed	Head up operation * See p. 48	Proper operation can be achieved.
		There must not be any strange noises.
	Knee up operation * See p. 48	Proper operation can be achieved.
		There must not be any strange noises.
	Height adjustment operation * See p. 49	Proper operation can be achieved.
		There must not be any strange noises or significant rattling.
Bed operation buttons * See p. 59 to 66	All bed operation buttons must work.	
CPR * See p. 74	The head section must be lowered with a CPR lever.	
Miscellaneous		There must not be any deformation, damage, or detachment of roller bumpers or resin parts.
		There must not be any peeling of labels, and the text must be legible.
		There must not be any scratches or deformation at the mattress deck, frame, or any other parts.
Board	Attachment state * See p. 28	The board stopper must be locked properly.
		There must not be any significant rattling.
Caster	Traveling	There must not be any strange noises when the bed is traveling.
		There must not be any abnormal vibrations when the bed is traveling.
	Caster locking operation * See p. 33	Proper operation can be achieved.
		The operation must not be overly difficult.
Side-rail	Side-rail operation * See p. 29 and 30	The bed must not move when casters are locked.
		The bed must move smoothly when the lock is released.
Electrical components	Visual check of electrical components	Proper operation can be achieved.
		There must not be any strange noises or significant rattling.
		The operation must not be overly difficult.
		Cables must not get tangled in the bed.
	Nurse call notification check (only when using the nurse call auxiliary button of the bed)	The plug and the cable must have no scratches or damage.
The side-rail integrated panel, patient control panel, DS display panel, and hand-held controller (accessory) must have no scratches or damage.		
		The pins of the bed side connector (37-pin male) must not be damaged.
		The LED lamp above the nurse call auxiliary button must turn on and a nurse call must be made when the nurse call auxiliary button is pressed while the bed is connected to the nurse call wall plate.

5 REFERENCE INFORMATION

Daily maintenance



WARNING

- To prevent accidents caused by incorrect operation, always disconnect the power plug from the outlet before maintenance.
- Do not clean the bed by pouring water onto it. Short circuit and electric shock may occur.

<Bed>

■ When removing stains from parts

Perform steps 1 to 3 below.

1. Wipe off stains with a cloth soaked in a neutral detergent diluted with water and wrung out well.
2. Wipe off any residual detergent with a cloth soaked in water and wrung out well.
3. Wipe away any leftover moisture with a dry cloth.

■ When disinfecting parts

Use one of the disinfectants listed below at the specified concentrations by following the instructions in the instruction manual for the disinfectant.

Up to 81.4%	Ethanol for disinfection
Up to 0.2%	Benzalkonium chloride (e.g., Osvan)
Up to 0.2%	Benzethonium chloride (e.g., Hyamine)
Up to 0.05%	Chlorhexidine gluconate (e.g., Hibitane)
Up to 1.0%	Sodium hypochlorite (e.g., Milton)

* It is recommended to disinfect the bed before another patient uses the bed.



CAUTION

- Do not use volatile cleaning solutions (such as paint thinner, benzene, or gasoline) or cresol. Discoloration or deterioration may result.
- Do not use disinfectants other than those listed above. Damage or deterioration may result.
- Thoroughly wipe off parts with a damp cloth after using a neutral detergent or sodium hypochlorite. Not doing so may cause cracking, discoloration, or deterioration of the resin.



Do not sterilize. The bed is not intended for sterilization and has not been tested for compatibility with healthcare sterilization systems including ozone, moist heat/steam, dry heat, ethylene oxide vaporized Hydrogen peroxide and other chemical sterilizers. Exposure of the bed to these processes may damage the bed and render it non-functional.

<Suitable products, etc.>

Follow the instructions described in the instruction manual supplied with the respective suitable product.

<Mattress>

Follow the instructions described in the instruction manual supplied with the mattress.

2. Long-term storage and disposal

Long-term storage

The following precautions should be observed when the bed will not be in use for an extended period of time.

- Turn off BED EXIT ALARM notification.
- Lay the head and knee sections flat.
- Lower the bed height to the minimum height.
- Do not place objects other than a mattress on the bed.
- Do not place any objects on the mattress.
- Avoid a location subject to high temperature or humidity, low temperature, dryness or excessive dust. Store the bed at a temperature between -10°C and 50°C , humidity between 30% RH and 90% RH and atmospheric pressure between 620 hPa and 1060 hPa.
- Do not lean the bed against a wall, but store it level on the floor.
- Be sure to disconnect the power plug from the outlet and bundle the power cable in a location where the cable is not pinched or stepped on.
- Turn the battery off.

Product disposal

When the A6 Series has reached the end of its usable life, dispose of it according to the local rules and regulations.

A gas spring attached to the head section is a part filled with high-pressure gas. When disposing of a gas spring, dispose of it properly according to the following precautions.

- Drill a hole in the lowermost part of the gas spring cylinder to release all of the gas. (Refer to the figure below.)
- Wear safety goggles and other protective equipment because chips and oil may fly off when releasing the gas.

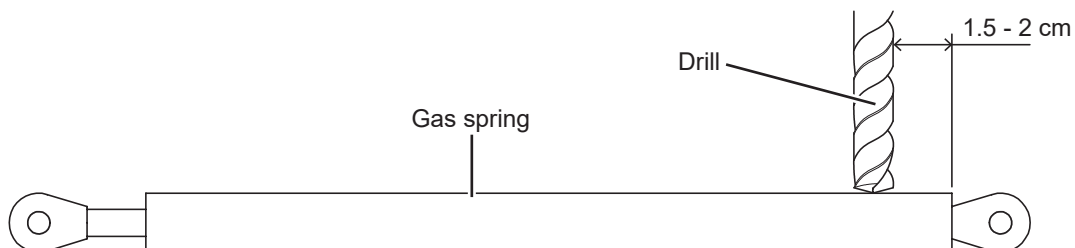

5 REFERENCE INFORMATION

3. Specifications

<125 mm single-wheel with resin cover>

Family name		A6 Series Bed			
Product name		Electrical Hospital Bed with Digital Scale			
Model No.		PA-H 6415	PA-H 6435	PA-H 6415 X ^{*1)}	PA-H 6435 X ^{*1)}
Foot-end side-rail		Full length	Short length	Full length	Short length
Dimensions (cm)	Total length (min. — max.)	222 to 252	222 to 238	222 to 252	222 to 238
	Total width	99			
	Total height	81.3 [+2, -1] to 126.3 [±1.5]			
	Mattress deck length	200			
	Mattress deck height ^{*2)}	40.8 [+2, -1] to 85.8 [±1.5]			
Power cable length		Effective length 300 cm			
Product weight (kg)		172	170	177	175
Maximum user weight		180 kg			
Safe working load ^{*3)}		255 kg (2500 N)			
Guaranteed operating conditions	Temperature	10 to 40°C (when using BED EXIT ALARM: 15 to 30°C)			
	Humidity	30 to 75% RH			
	Atmospheric pressure	620 to 1060 hPa			
Transport and storage conditions	Temperature	-10 to 50°C			
	Humidity	30 to 90% RH			
	Atmospheric pressure	620 to 1060 hPa			
Service life		8 years (based on Paramount Bed data) * On condition that you perform the specified maintenance and inspection and replace the consumable parts (e.g., casters).			
Materials	Headboard/ footboard	HDPE resin molding			
	Bed side-rail	HDPE resin molding			
	Roller bumper	EPDM resin molding			
	Head mattress deck (without X-ray cassette tray)	HDPE resin molding	-		
	Head mattress deck (with X-ray cassette tray)	-	Phenolic resin		
	Hip/knee/leg mattress deck	HDPE resin molding			
	Main frame	Powder coated steel			
	Control panel	PET resin molding			
Operating principles		Link mechanism using expansion and contraction of electric linear actuator			
Head up	Inclination angle	0 to 70 ±7°			
	Required time	30 seconds			
Knee up	Inclination angle	0 to 25 ±4°			
	Required time	7 seconds			
	Switching angle of leg section	0 to 10 ±2°			
Height up/down	Range	45 cm			
	Required time ^{*4)}	35 seconds			
Trendelenburg/ Reverse Trendelenburg	Inclination angle	0 to 15 ±2°			
	Required time	16 seconds			

■ Frequently used functions

Head up, knee up, height adjustment, side-rail raising/lowering operations

* IEC 60601-2-52:2009+AMD1:2015 application environments 1 and 2

- *1) Beds with an "X" at the end of the part number come standard with an X-ray cassette tray.
- *2) Bottom height indicates the height from the floor to the top of the bottom.
- *3) Safe working load: Load that can safely use the bed.
(Weight of the user and the total weight of accessories such as mattresses and suitable products)
- *4) When the shaking reaches a height of 43 cm from the floor to the top of the bottom, a warning sound is heard and the shaking stops for safety reasons. Press the height button again to sweep to the lowest height with a warning sound.

Electrical components	Type		Linear actuator (DC motor)
	Power supply voltage/ frequency		100 to 240 VAC, 50/60 Hz
	Power consumption		Head up: 255 VA or less Knee up: 190 VA or less Height adjustment: 560 VA or less
	Maximum continuous operating time		2 min. (downtime: 38 min.)*5)
	Rated USB output		5 V/1 A
	Operating		45 dB or less*6)
	Fuse	Control box	250 VAC, 6.3 A, delay type, interrupting capacity: 100 A or more
	Battery specifications	Type/quantity	Small sealed lead acid battery (12 VDC/1.2 Ah) x2
		Rating	24 VDC/1.2 Ah (10 hour rate)
	Materials	Handheld controller (accessory)	Front case: PPE/PS resin moldings, Rear case: ASA resin moldings, Hook/Cable clip: POM resin molding, Cable: PVC resin molding

*5) Time to protect electrical components from overheating when the bed is used continuously for maximum continuous operating time.

*6) Based on the internal metrics.

Weight scale	Maximum capacity (max.)	255 kg
	Verification scale interval (e)	0.1 kg
	Maximum tare effect (T)*7)	-255 kg
	Temperature limits	5°C / 40°C
	Data backup function*8)	Available

*7) Maximum tare weight that can be subtracted.

*8) Even if a power failure occurs or the power plug is disconnected by mistake while measuring weight changes, the data during measurement is restored when power is recovered.

5 REFERENCE INFORMATION

<125 mm single-wheel with iron cover (total lock)>

Family name		A6 Series Bed			
Product name		Electrical Hospital Bed with Digital Scale			
Model No.		PA-H 6417	PA-H 6437	PA-H 6417 X ^{*1)}	PA-H 6437 X ^{*1)}
Foot-end side-rail		Full length	Short length	Full length	Short length
Dimensions (cm)	Total length (min. — max.)	222 to 252	222 to 238	222 to 252	222 to 238
	Total width	99			
	Total height	81.8 [+2, -1] to 126.8 [±1.5]			
	Mattress deck length	200			
	Mattress deck height ^{*2)}	41.3 [+2, -1] to 86.3 [±1.5]			
Power cable length		Effective length 300 cm			
Product weight (kg)		172	170	177	175
Maximum user weight		180 kg			
Safe working load ^{*3)}		255 kg (2500 N)			
Guaranteed operating conditions	Temperature	10 to 40°C (when using BED EXIT ALARM: 15 to 30°C)			
	Humidity	30 to 75% RH			
	Atmospheric pressure	620 to 1060 hPa			
Transport and storage conditions	Temperature	-10 to 50°C			
	Humidity	30 to 90% RH			
	Atmospheric pressure	620 to 1060 hPa			
Service life		8 years (based on Paramount Bed data) * On condition that you perform the specified maintenance and inspection and replace the consumable parts (e.g., casters).			
Materials	Headboard/footboard	HDPE resin molding			
	Bed side-rail	HDPE resin molding			
	Roller bumper	EPDM resin molding			
	Head mattress deck (without X-ray cassette tray)	HDPE resin molding		-	
	Head mattress deck (with X-ray cassette tray)	-		Phenolic resin	
	Hip/knee/leg mattress deck	HDPE resin molding			
	Main frame	Powder coated steel			
	Control panel	PET resin molding			
Operating principles		Link mechanism using expansion and contraction of electric linear actuator			
Head up	Inclination angle	0 to 70 ±7°			
	Required time	30 seconds			
Knee up	Inclination angle	0 to 25 ±4°			
	Required time	7 seconds			
	Switching angle of leg section	0 to 10 ±2°			
Height up/down	Range	45 cm			
	Required time ^{*4)}	35 seconds			
Trendelenburg/Reverse Trendelenburg	Inclination angle	0 to 15 ±2°			
	Required time	16 seconds			

■ Frequently used functions

Head up, knee up, height adjustment, side-rail raising/lowering operations

* IEC 60601-2-52:2009+AMD1:2015 application environments 1 and 2

- *1) Beds with an “X” at the end of the part number come standard with an X-ray cassette tray.
- *2) Bottom height indicates the height from the floor to the top of the bottom.
- *3) Safe working load: Load that can safely use the bed.
(Weight of the user and the total weight of accessories such as mattresses and suitable products)
- *4) When the shaking reaches a height of 43 cm from the floor to the top of the bottom, a warning sound is heard and the shaking stops for safety reasons. Press the height button again to sweep to the lowest height with a warning sound.

Electrical components	Type		Linear actuator (DC motor)
	Power supply voltage/ frequency		100 to 240 VAC, 50/60 Hz
	Power consumption		Head up: 255 VA or less Knee up: 190 VA or less Height adjustment: 560 VA or less
	Maximum continuous operating time		2 min. (downtime: 38 min.)*5)
	Rated USB output		5 V/1 A
	Operating		45 dB or less*6)
	Fuse	Control box	250 VAC, 6.3 A, delay type, interrupting capacity: 100 A or more
	Battery specifications	Type/quantity	Small sealed lead acid battery (12 VDC/1.2 Ah) x2
		Rating	24 VDC/1.2 Ah (10 hour rate)
	Materials	Handheld controller (accessory)	Front case: PPE/PS resin moldings, Rear case: ASA resin moldings, Hook/Cable clip: POM resin molding, Cable: PVC resin molding

*5) Time to protect electrical components from overheating when the bed is used continuously for maximum continuous operating time.

*6) Based on the internal metrics.

Weight scale	Maximum capacity (max.)	255 kg
	Verification scale interval (e)	0.1 kg
	Maximum tare effect (T)*7)	-255 kg
	Temperature limits	5°C / 40°C
	Data backup function*8)	Available

*7) Maximum tare weight that can be subtracted.

*8) Even if a power failure occurs or the power plug is disconnected by mistake while measuring weight changes, the data during measurement is restored when power is recovered.

5 REFERENCE INFORMATION

<125 mm double-wheel with resin cover>

Family name		A6 Series Bed			
Product name		Electrical Hospital Bed with Digital Scale			
Model No.		PA-H 6418	PA-H 6438	PA-H 6418 X ^{*1)}	PA-H 6438 X ^{*1)}
Foot-end side-rail		Full length	Short length	Full length	Short length
Dimensions (cm)	Total length (min. — max.)	222 to 252	222 to 238	222 to 252	222 to 238
	Total width	99			
	Total height	80.5 [+2, -1] to 125.5 [±1.5]			
	Mattress deck length	200			
	Mattress deck height ^{*2)}	40 [+2, -1] to 85 [±1.5]			
Power cable length		Effective length 300 cm			
Product weight (kg)		172	170	177	175
Maximum user weight		180 kg			
Safe working load ^{*3)}		255 kg (2500 N)			
Guaranteed operating conditions	Temperature	10 to 40°C (when using BED EXIT ALARM: 15 to 30°C)			
	Humidity	30 to 75% RH			
	Atmospheric pressure	620 to 1060 hPa			
Transport and storage conditions	Temperature	-10 to 50°C			
	Humidity	30 to 90% RH			
	Atmospheric pressure	620 to 1060 hPa			
Service life		8 years (based on Paramount Bed data) * On condition that you perform the specified maintenance and inspection and replace the consumable parts (e.g., casters).			
Materials	Headboard/footboard	HDPE resin molding			
	Bed side-rail	HDPE resin molding			
	Roller bumper	EPDM resin molding			
	Head mattress deck (without X-ray cassette tray)	HDPE resin molding	-		
	Head mattress deck (with X-ray cassette tray)	-	Phenolic resin		
	Hip/knee/leg mattress deck	HDPE resin molding			
	Main frame	Powder coated steel			
	Control panel	PET resin molding			
Operating principles		Link mechanism using expansion and contraction of electric linear actuator			
Head up	Inclination angle	0 to 70 ±7°			
	Required time	30 seconds			
Knee up	Inclination angle	0 to 25 ±4°			
	Required time	7 seconds			
	Switching angle of leg section	0 to 10 ±2°			
Height up/down	Range	45 cm			
	Required time ^{*4)}	35 seconds			
Trendelenburg/Reverse Trendelenburg	Inclination angle	0 to 15 ±2°			
	Required time	16 seconds			

■ Frequently used functions

Head up, knee up, height adjustment, side-rail raising/lowering operations

* IEC 60601-2-52:2009+AMD1:2015 application environments 1 and 2

- *1) Beds with an “X” at the end of the part number come standard with an X-ray cassette tray.
- *2) Bottom height indicates the height from the floor to the top of the bottom.
- *3) Safe working load: Load that can safely use the bed.
(Weight of the user and the total weight of accessories such as mattresses and suitable products)
- *4) When the shaking reaches a height of 43 cm from the floor to the top of the bottom, a warning sound is heard and the shaking stops for safety reasons. Press the height button again to sweep to the lowest height with a warning sound.

Electrical components	Type		Linear actuator (DC motor)
	Power supply voltage/ frequency		100 to 240 VAC, 50/60 Hz
	Power consumption		Head up: 255 VA or less Knee up: 190 VA or less Height adjustment: 560 VA or less
	Maximum continuous operating time		2 min. (downtime: 38 min.)*5)
	Rated USB output		5 V/1 A
	Operating		45 dB or less*6)
	Fuse	Control box	250 VAC, 6.3 A, delay type, interrupting capacity: 100 A or more
	Battery specifications	Type/quantity	Small sealed lead acid battery (12 VDC/1.2 Ah) x2
		Rating	24 VDC/1.2 Ah (10 hour rate)
	Materials	Handheld controller (accessory)	Front case: PPE/PS resin moldings, Rear case: ASA resin moldings, Hook/Cable clip: POM resin molding, Cable: PVC resin molding

*5) Time to protect electrical components from overheating when the bed is used continuously for maximum continuous operating time.

*6) Based on the internal metrics.

Weight scale	Maximum capacity (max.)	255 kg
	Verification scale interval (e)	0.1 kg
	Maximum tare effect (T)*7)	-255 kg
	Temperature limits	5°C / 40°C
	Data backup function*8)	Available

*7) Maximum tare weight that can be subtracted.

*8) Even if a power failure occurs or the power plug is disconnected by mistake while measuring weight changes, the data during measurement is restored when power is recovered.

5 REFERENCE INFORMATION

<125 mm single-wheel with iron cover (individual lock)>

Family name		A6 Series Bed			
Product name		Electrical Hospital Bed with Digital Scale			
Model No.		PA-H 6419	PA-H 6439	PA-H 6419 X ^{*1)}	PA-H 6439 X ^{*1)}
Foot-end side-rail		Full length	Short length	Full length	Short length
Dimensions (cm)	Total length (min. — max.)	222 to 252	222 to 238	222 to 252	222 to 238
	Total width	99			
	Total height	81.8 [+2, -1] to 126.8 [±1.5]			
	Mattress deck length	200			
	Mattress deck height ^{*2)}	41.3 [+2, -1] to 86.3 [±1.5]			
Power cable length		Effective length 300 cm			
Product weight (kg)		172	170	177	175
Maximum user weight		180 kg			
Safe working load ^{*3)}		255 kg (2500 N)			
Guaranteed operating conditions	Temperature	10 to 40°C (when using BED EXIT ALARM: 15 to 30°C)			
	Humidity	30 to 75% RH			
	Atmospheric pressure	620 to 1060 hPa			
Transport and storage conditions	Temperature	-10 to 50°C			
	Humidity	30 to 90% RH			
	Atmospheric pressure	620 to 1060 hPa			
Service life		8 years (based on Paramount Bed data) * On condition that you perform the specified maintenance and inspection and replace the consumable parts (e.g., casters).			
Materials	Headboard/ footboard	HDPE resin molding			
	Bed side-rail	HDPE resin molding			
	Roller bumper	EPDM resin molding			
	Head mattress deck (without X-ray cassette tray)	HDPE resin molding	-		
	Head mattress deck (with X-ray cassette tray)	-	Phenolic resin		
	Hip/knee/leg mattress deck	HDPE resin molding			
	Main frame	Powder coated steel			
	Control panel	PET resin molding			
Operating principles		Link mechanism using expansion and contraction of electric linear actuator			
Head up	Inclination angle	0 to 70 ±7°			
	Required time	30 seconds			
Knee up	Inclination angle	0 to 25 ±4°			
	Required time	7 seconds			
	Switching angle of leg section	0 to 10 ±2°			
Height up/down	Range	45 cm			
	Required time ^{*4)}	35 seconds			
Trendelenburg/ Reverse Trendelenburg	Inclination angle	0 to 15 ±2°			
	Required time	16 seconds			

■ Frequently used functions

Head up, knee up, height adjustment, side-rail raising/lowering operations

* IEC 60601-2-52:2009+AMD1:2015 application environments 1 and 2

- *1) Beds with an "X" at the end of the part number come standard with an X-ray cassette tray.
- *2) Bottom height indicates the height from the floor to the top of the bottom.
- *3) Safe working load: Load that can safely use the bed.
(Weight of the user and the total weight of accessories such as mattresses and suitable products)
- *4) When the shaking reaches a height of 43 cm from the floor to the top of the bottom, a warning sound is heard and the shaking stops for safety reasons. Press the height button again to sweep to the lowest height with a warning sound.

Electrical components	Type		Linear actuator (DC motor)
	Power supply voltage/ frequency		100 to 240 VAC, 50/60 Hz
	Power consumption		Head up: 255 VA or less Knee up: 190 VA or less Height adjustment: 560 VA or less
	Maximum continuous operating time		2 min. (downtime: 38 min.)*5)
	Rated USB output		5 V/1 A
	Operating		45 dB or less*6)
	Fuse	Control box	250 VAC, 6.3 A, delay type, interrupting capacity: 100 A or more
	Battery specifications	Type/quantity	Small sealed lead acid battery (12 VDC/1.2 Ah) x2
		Rating	24 VDC/1.2 Ah (10 hour rate)
	Materials	Handheld controller (accessory)	Front case: PPE/PS resin moldings, Rear case: ASA resin moldings, Hook/Cable clip: POM resin molding, Cable: PVC resin molding

*5) Time to protect electrical components from overheating when the bed is used continuously for maximum continuous operating time.

*6) Based on the internal metrics.

Weight scale	Maximum capacity (max.)	255 kg
	Verification scale interval (e)	0.1 kg
	Maximum tare effect (T)*7)	-255 kg
	Temperature limits	5°C / 40°C
	Data backup function*8)	Available

*7) Maximum tare weight that can be subtracted.

*8) Even if a power failure occurs or the power plug is disconnected by mistake while measuring weight changes, the data during measurement is restored when power is recovered.

5 REFERENCE INFORMATION

<150 mm single-wheel with resin cover>

Family name		A6 Series Bed			
Product name		Electrical Hospital Bed with Digital Scale			
Model No.		PA-H 6410	PA-H 6430	PA-H 6410 X ^{*1)}	PA-H 6430 X ^{*1)}
Foot-end side-rail		Full length	Short length	Full length	Short length
Dimensions (cm)	Total length (min. — max.)	222 to 252	222 to 238	222 to 252	222 to 238
	Total width	99			
	Total height	83.8 [+2, -1] to 128.8 [±1.5]			
	Mattress deck length	200			
	Mattress deck height ^{*2)}	43.8 [+2, -1] to 88.8 [±1.5]			
Power cable length		Effective length 300 cm			
Product weight (kg)		172	170	177	175
Maximum user weight		180 kg			
Safe working load ^{*3)}		255 kg (2500 N)			
Guaranteed operating conditions	Temperature	10 to 40°C (when using BED EXIT ALARM: 15 to 30°C)			
	Humidity	30 to 75% RH			
	Atmospheric pressure	620 to 1060 hPa			
Transport and storage conditions	Temperature	-10 to 50°C			
	Humidity	30 to 90% RH			
	Atmospheric pressure	620 to 1060 hPa			
Service life		8 years (based on Paramount Bed data) * On condition that you perform the specified maintenance and inspection and replace the consumable parts (e.g., casters).			
Materials	Headboard/footboard	HDPE resin molding			
	Bed side-rail	HDPE resin molding			
	Roller bumper	EPDM resin molding			
	Head mattress deck (without X-ray cassette tray)	HDPE resin molding	-		
	Head mattress deck (with X-ray cassette tray)	-	Phenolic resin		
	Hip/knee/leg mattress deck	HDPE resin molding			
	Main frame	Powder coated steel			
	Control panel	PET resin molding			
Operating principles		Link mechanism using expansion and contraction of electric linear actuator			
Head up	Inclination angle	0 to 70 ±7°			
	Required time	30 seconds			
Knee up	Inclination angle	0 to 25 ±4°			
	Required time	7 seconds			
	Switching angle of leg section	0 to 10 ±2°			
Height up/down	Range	45 cm			
	Required time ^{*4)}	35 seconds			
Trendelenburg/Reverse Trendelenburg	Inclination angle	0 to 15 ±2°			
	Required time	16 seconds			

■ Frequently used functions

Head up, knee up, height adjustment, side-rail raising/lowering operations

* IEC 60601-2-52:2009+AMD1:2015 application environments 1 and 2

- *1) Beds with an "X" at the end of the part number come standard with an X-ray cassette tray.
- *2) Bottom height indicates the height from the floor to the top of the bottom.
- *3) Safe working load: Load that can safely use the bed.
(Weight of the user and the total weight of accessories such as mattresses and suitable products)
- *4) When the shaking reaches a height of 43 cm from the floor to the top of the bottom, a warning sound is heard and the shaking stops for safety reasons. Press the height button again to sweep to the lowest height with a warning sound.

Electrical components	Type		Linear actuator (DC motor)
	Power supply voltage/ frequency		100 to 240 VAC, 50/60 Hz
	Power consumption		Head up: 255 VA or less Knee up: 190 VA or less Height adjustment: 560 VA or less
	Maximum continuous operating time		2 min. (downtime: 38 min.)*5)
	Rated USB output		5 V/1 A
	Operating		45 dB or less*6)
	Fuse	Control box	250 VAC, 6.3 A, delay type, interrupting capacity: 100 A or more
	Battery specifications	Type/quantity	Small sealed lead acid battery (12 VDC/1.2 Ah) x2
		Rating	24 VDC/1.2 Ah (10 hour rate)
	Materials	Handheld controller (accessory)	Front case: PPE/PS resin moldings, Rear case: ASA resin moldings, Hook/Cable clip: POM resin molding, Cable: PVC resin molding

*5) Time to protect electrical components from overheating when the bed is used continuously for maximum continuous operating time.

*6) Based on the internal metrics.

Weight scale	Maximum capacity (max.)	255 kg
	Verification scale interval (e)	0.1 kg
	Maximum tare effect (T)*7)	-255 kg
	Temperature limits	5°C / 40°C
	Data backup function*8)	Available

*7) Maximum tare weight that can be subtracted.

*8) Even if a power failure occurs or the power plug is disconnected by mistake while measuring weight changes, the data during measurement is restored when power is recovered.

5 REFERENCE INFORMATION

● Essential performance

Function to support the body of patient, Emergency CPR (head down) function.

● Classification and Standards

The electric hospital bed is designed and manufactured according to the following equipment classification and standards.

- Safety standards applied
 - : IEC 60601-1:2005+AMD1:2012+AMD2:2020
 - : IEC 60601-1-2:2014+AMD1:2020
 - : IEC 60601-2-52:2009+AMD1:2015 for use with IEC 60601-1:2005
 - : EN 60601-1:2006+A1:2013+A2:2021
 - : EN 60601-1-2:2015+A1:2021
 - : EN 60601-2-52:2010+A1:2015
- Electric shock protection : Class 1, Type B
- Application environment (in IEC 60601-2-52:2009+AMD1:2015) : 1 and 2
- Protection code : IEC 60529 IPX4

* Equipment not suitable for use in the presence of a flammable anaesthetic mixture.

<Casters>

Type	Total height (cm)	Height of mattress deck top surface (cm)
125 mm single-wheel with resin cover	81.3 [+2, -1] to 126.3 [±1.5]	40.8 [+2, -1] to 85.8 [±1.5]
125 mm single-wheel with iron cover (total lock)	81.8 [+2, -1] to 126.8 [±1.5]	41.3 [+2, -1] to 86.3 [±1.5]
125 mm double-wheel with resin cover	80.5 [+2, -1] to 125.5 [±1.5]	40 [+2, -1] to 85 [±1.5]
125 mm single-wheel with iron cover (individual lock)	81.8 [+2, -1] to 126.8 [±1.5]	41.3 [+2, -1] to 86.3 [±1.5]
150 mm single-wheel with resin cover	83.8 [+2, -1] to 128.8 [±1.5]	43.8 [+2, -1] to 88.8 [±1.5]

4. Technical explanation regarding EMD (Electromagnetic Disturbance)

The bed requires special safety precautions regarding EMC to be observed. Install, operate, and use the bed according to the information provided below.

The bed is intended for use in an electromagnetic environment specified according to “Electromagnetic interference.” Using the bed in an unintended environment may result in the occurrence of the following problems.

- The function for supporting the patient’s body weight may not be maintained.
- The emergency head down function may not be maintained.

No.	Cable	Maximum length [m]	Remarks
1	AC power cable	3.5	Without shield
2	Handheld controller cable of type with a handheld controller	1.2	Without shield
3	Handheld controller cable (RC-1850E: accessory)	0.6	Without shield

The bed is intended for use in doctor’s offices, clinics, exclusive medical facilities, independent surgery centers, multiple treatment facilities, hospitals (except near high-frequency surgical equipment, and outside RF shielded rooms for magnetic resonance images). The customers or users of the bed must ensure that the bed is always used in this environment.

Due to its emission characteristics, the bed is suitable for use in hospitals. If used in a home environment, this device may not offer sufficient protection against radio frequency communication services.

It may be necessary for the user to take relaxation measures such as re-arranging or changing the direction of the device.

 WARNING	<ul style="list-style-type: none"> ● If accessories, transducers, or cables other than those specified and sold by the manufacturers of the bed are used as replacement parts for internal components, it may result in an increase in emission or a decline in immunity of the bed. ● Use portable RF communication devices (including antenna cables and peripheral devices such as external antennas) at a distance of at least 30 cm from all parts of the bed. Using the RF communication devices within a distance of 30 cm may cause a decline in the performance of the bed. ● The bed cannot be used adjacent to another device or in a stacked state. If the bed must be used adjacent to another device or in a stacked state, make sure the bed operates appropriately at the location of use.
--	--

Guidance and manufacturer’s declaration — electromagnetic emissions		
The bed is intended for use in the electromagnetic environments specified below. The customer or the user of the bed must use it in an environment specified here.		
Emission test	Compliance	Electromagnetic environment — guidance
RF emissions CISPR 11	Group 1	The bed uses RF energy only for its internal functions. Therefore, its RF emissions are low and are not likely to cause any interference with nearby electronic equipment. Use the bed in a power supply network of a professional environment, such as a hospital or other medical facility.
RF emissions CISPR 11	Class A	
Harmonic emissions IEC 61000-3-2	N/A	
Voltage fluctuations / flicker emissions IEC 61000-3-3	N/A	

5 REFERENCE INFORMATION

Guidance and manufacturer's declaration — electromagnetic immunity		
The bed is intended for use in the following electromagnetic environment. The customer or user of the bed must use it in an environment specified here.		
Immunity test	IEC 60601-1-2 Test level	Compliance level
Electrostatic discharge (ESD) IEC 61000-4-2	Contact discharge: ± 8 kV Air discharge: ± 2 kV, ± 4 kV, ± 8 kV, ± 15 kV	Contact discharge: ± 8 kV Air discharge: ± 2 kV, ± 4 kV, ± 8 kV, ± 15 kV
Electrical fast transient/ burst IEC 61000-4-4	Power supply line: ± 2 kV Input/output lines: ± 1 kV	Power supply line: ± 2 kV Input/output lines: ± 1 kV
Surge IEC 61000-4-5	Line to line: ± 0.5 kV, ± 1.0 kV Line to earth: ± 0.5 kV, ± 1.0 kV, ± 2.0 kV	Line to line: ± 0.5 kV, ± 1.0 kV Line to earth: ± 0.5 kV, ± 1.0 kV, ± 2.0 kV
Voltage dips, instantaneous power failure, and voltage fluctuation in power supply cable IEC 61000-4-11	0.5 cycle for test level 0% U_T (Phase: at 0° , 45° , 90° , 135° , 180° , 225° , 270° and 315°)	0.5 cycle for test level 0% U_T (Phase: at 0° , 45° , 90° , 135° , 180° , 225° , 270° and 315°)
	1 cycle for test level 0% U_T and 25/30 cycles for test level 70% U_T (Single phase: at 0°)	1 cycle for test level 0% U_T and 25/30 cycles for test level 70% U_T (Single phase: at 0°)
Short-term power failure IEC 61000-4-11	250/300 cycles for test level 0% U_T	250/300 cycles for test level 0% U_T
Power frequency (50/60 Hz) magnetic field IEC 61000-4-8	30 A/m	30 A/m
Proximity Magnetic Fields IEC 61000-4-39	134.2 kHz, 50% Pulse at 2.1 kHz, 65 A/m 13.56 MHz, 50% Pulse at 50 kHz, 7.5 A/m	134.2 kHz, 50% Pulse at 2.1 kHz, 65 A/m 13.56 MHz, 50% Pulse at 50 kHz, 7.5 A/m
Note: U_T is the AC power voltage before applying the test level.		

Guidance and manufacturer's declaration — electromagnetic immunity

The bed is intended for use in the following electromagnetic environment. The customer or user of the bed must use it in an environment specified here.

Immunity test	IEC 60601-1-2 Test level	Compliance level	Electromagnetic environment — guidance
RF Conductivity IEC 61000-4-6	3 V 0.15 MHz to 80 MHz 6 V ISM bandwidth between 0.15 MHz and 80 MHz 80% amplitude modulation (1 kHz)	3 V 0.15 MHz to 80 MHz 6 V ISM bandwidth between 0.15 MHz and 80 MHz 80% amplitude modulation (1 kHz)	Field strengths from fixed RF transmitters, as determined by an electromagnetic site survey, must be less than the compliance level in each frequency range. Interference may occur in the vicinity of equipment marked with the following symbol:
Radioactive RF electromagnetic field IEC 61000-4-3	3 V/m 80 MHz to 2.7 GHz 80% amplitude modulation (1 kHz)	3 V/m 80 MHz to 2.7 GHz 80% amplitude modulation (1 kHz)	

- a. Field strengths from fixed transmitters, such as those of base stations for radio (cellular/cordless) telephones, land mobile radios, amateur radios, AM and FM radio broadcasts, and TV broadcasts cannot be predicted theoretically with accuracy. To determine the electromagnetic environment due to fixed RF transmitters, an electromagnetic survey of the site should be considered. If the measured field strength in the location in which bed is used exceeds the applicable RF compliance level above, bed should be observed to verify whether or not it is operating appropriately. If an abnormal operation is seen, take additional measures as needed, such as changing the location of use of the bed.
- b. These guidelines may not apply in all situations. Electromagnetic propagation is affected by absorption and reflection from structures, objects, and people.

5 REFERENCE INFORMATION

Guidance and manufacturer's declaration — electromagnetic immunity							
The bed is intended to be used in an electromagnetic environment where RF radio communication devices are used. The electromagnetic interference between the RF communication device and the bed can be prevented by maintaining the minimum distance between the two as recommended below in accordance with the maximum output and frequency of the communication device.							
Immunity test	IEC 60601-1-2 Test level	Compliance level	Bandwidth (MHz)	Service	Modulation	Maximum output (W)	Distance (m)
Proximate electromagnetic field IEC 61000-4-3	27 V/m 385 MHz	27 V/m	380 to 390	TETRA 400	Pulse modulation 18 Hz	1.8	0.3
	28 V/m 450 MHz	28 V/m	430 to 470	GMRS 460, FRS460	Pulse modulation 18 Hz	2	0.3
	9 V/m 710 MHz	9 V/m	704 to 787	LTE band 13, 17	Pulse modulation 217 Hz	0.2	0.3
	9 V/m 745 MHz						
	9 V/m 780 MHz						
	28 V/m 810 MHz	28 V/m	800 to 960	GSM 800/900, TETRA 800, iDen 820, CDMA 850, LTE band 5	Pulse modulation 18 Hz	2	0.3
	28 V/m 870 MHz						
	28 V/m 930 MHz						
	28 V/m 1720 MHz	28 V/m	1700 to 1990	GSM 1800; CDMA 1900; GSM 1900; DECT; LTE band 1, 3, 4, 25; UMTS	Pulse modulation 217 Hz	2	0.3
	28 V/m 1845 MHz						
	28 V/m 1970 MHz						
	28 V/m 2450 MHz	28 V/m	2400 to 2570	Bluetooth, WLAN, 802.11 b/g/n, RFID 2450, LTE band 7	Pulse modulation 217 Hz	2	0.3
	9 V/m 5240 MHz	9 V/m	5100 to 5800	WLAN 802.11 a/n	Pulse modulation 217 Hz	0.2	0.3
	9 V/m 5500 MHz						
	9 V/m 5785 MHz						

5. After-sales service

1. When requesting repairs

If you encounter trouble, perform troubleshooting according to the procedure described in “1. Troubleshooting” (see p. 98 to 101) in this instruction manual. If the problem persists after taking corrective action, disconnect the power plug of the bed from the outlet and turn the battery off, and then contact Paramount Bed (see Contact Information below) or your distributor.

■ Details necessary when requesting repair

- Product name, model number, number on product ID label (see p. 101 for the label location)
- Date of purchase
- Details of failure or problem (provide as much detail as possible)
- Facility name, your name, address, and phone number

■ Consumable parts

The following are consumable parts: casters, handheld controller (standard or accessory), USB cover, USB port, mattress deck fixing clip, gas spring, side-rail damper, side-rail integrated panel, patient control panel, and battery.



2. Minimum parts retention period

The minimum retention period of service functional parts (required to maintain the original functions of products) is 8 years after discontinuation of manufacturing.

3. When you are not sure about the after-sales service

For any queries, please feel free to contact your distributor or to the following address.

Contact Information

[Location in Japan (Manufacturer)]	[Location in Indonesia (Manufacturing premises)]
 PARAMOUNT BED CO., LTD. 14-5, 2-chome, Higashisuna, Koto-ku, Tokyo, 136-8670, Japan TEL : +81-(0)3-3648-2961 FAX : +81-(0)3-3648-5781	 PT. PARAMOUNT BED INDONESIA MM2100 Industrial Town, Block M-1-1, Gandamekar, Cikarang Barat, Bekasi 17530, Jawa Barat, Indonesia TEL : +62-(0)21-898-1051 FAX : +62-(0)21-8998-1611

For other contact information, please visit the website.
 Website: <https://www.paramount.co.jp/english/>



The SIAA mark is displayed on products for which quality management and information have been published in the guidelines of Society of International sustaining growth for Antimicrobial Articles based on results evaluated according to the ISO22196 method.

Inorganic antimicrobial agent/kneading: Headboard, footboard, side-rails, and mattress deck
 Inorganic antimicrobial agent/coating: Sheet switch
 JP0122394A0002Y



PARAMOUNT BED